

Industrial Inverter for Fan and Pump **STARVERT iP5A**

5.5~30kW(7.5~40HP) 3Phase 200~230Volts
5.5~450kW(7.5~600HP) 3Phase 380~480Volts



Automation Equipment



**SERVICE
ELETTRONICA
INDUSTRIALE**

LS Industrial Systems
www.lsis.biz



STARVERT iP5A

LS Starvert iP5A is basically created for centrifugal fan and pump, so iP5A can help construct competitive system in your various applications.



Specialized Functions for Fan and Pump

Energy Saving and High Efficiency

STARVERT iP5A

User-friendly Interface and Easy Maintenance

Intelligent Control Mechanism

Contents

4	Overview
8	Model & Type
9	Standard Specifications
11	Wiring
15	Terminal Configurations (Power Circuit Terminal)
17	Terminal Configurations (Control Circuit Terminal)
20	Programming Keypad
21	Programming Keypad (Parameter Navigation)
22	Parameter Description
33	Trial Run
35	Dimensions
40	DB (Dynamic Braking) Unit
45	External DB Resistor / Peripheral Device



Specialized Functions for Fan and Pump

iP5A is designed for Fans and Centrifugal Pumps. So it can support system stability and cost effectiveness to meet customer needs.



PID Control

In the centrifugal fan and pump field, PID control is provided as a standard function in order to maintain a constant process control of pressure, flow and oil level. This function includes Pre-PID, Sleep and Wake up and output inverse sub-functions.

Dual PID

In case of an external PID control needed or cascade PID control, the built-in Dual PID function of iP5A can construct various systems.

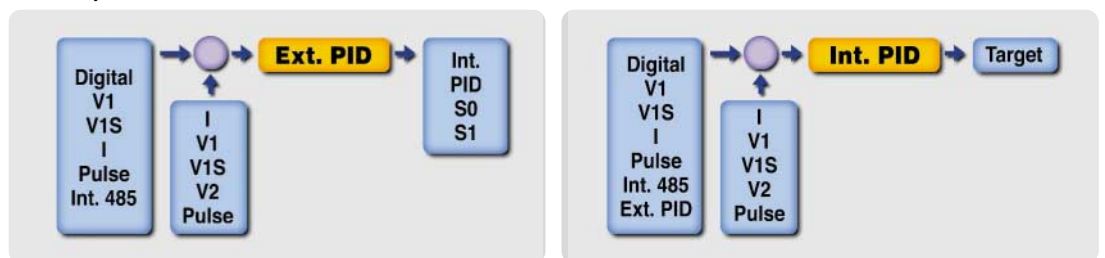

Multi Motor Control (5.5~90kW)

With this Multi Motor Control function, a number of motors can be controlled simultaneously without having any extra controllers. MMC function surely provides energy savings and cost down effect.

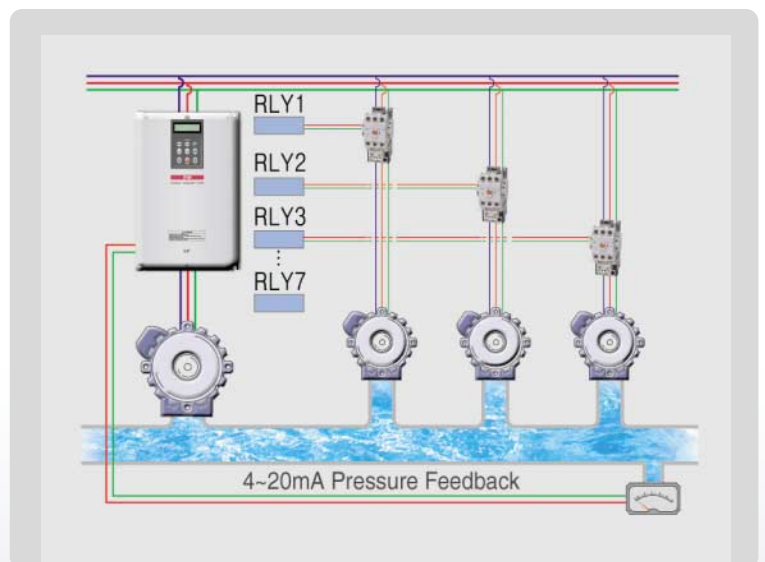

Energy Saving and High Efficiency

iP5A, uniquely designed for fan and pump, guarantees a certain degree of energy saving by realizing system effectiveness optimization.



Sleep and Wake-up Function

Sleep and Wake-up function can stop inverter's operation in extremely low weighted load situation. And if the load is restored to a normal situation, inverter will restart. This mechanism ultimately brings energy saving result of entire system.

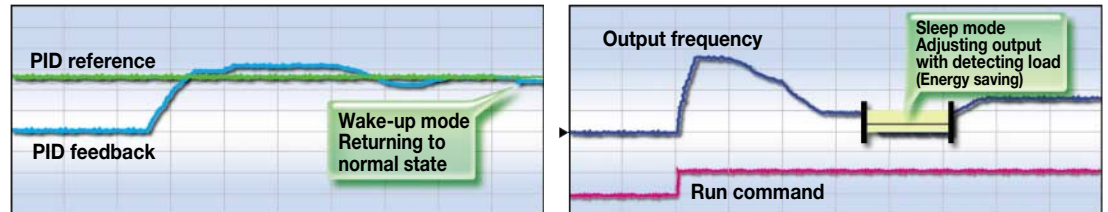

Pre Heating Function

When inverter is used in damp places such as green-house, this function can protect motor from damage and inverter's failure from damp.



Flying Start Function

In case of more than 2 fans operated in one system or heavy fan spinning by inertia, iP5A detects motor's speed and is able to control motor effectively.



Automatic Energy Saving

Load change may incur energy losses but the optimized flux control of iP5A results in more outstanding energy saving compared to previous models.

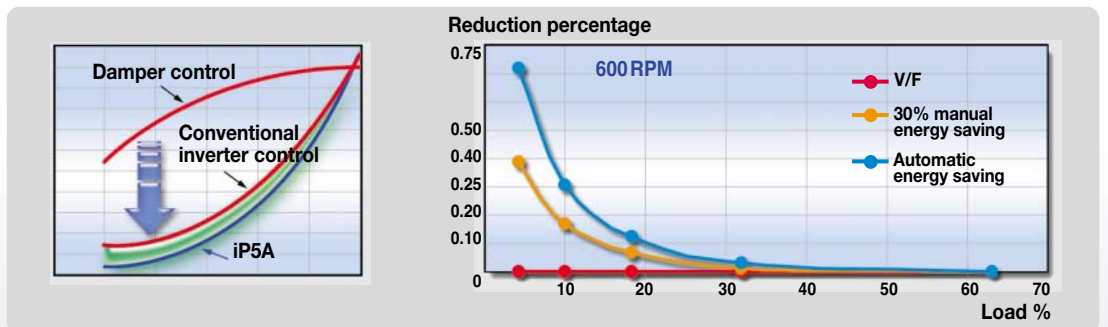

Intelligent Control

Regardless of outside alteration affecting inverter's performance, iP5A generates constant performance with effectual functions and protection methods.



Constant and Stable Performance

Regardless of outside alteration such as input voltage variation by load change or weather effect, iP5A can handle motor and load with best performance.



Improved Management from Instant Power-off and Power Dip Generation

During the power Dip or instant power-off, which is generated by lightening, ground fault and power-failure, loads still keep the mechanical energy and this energy flows back to inverter by regeneration. The power-failure guarantee time is extended by using this electrical character of inverter.

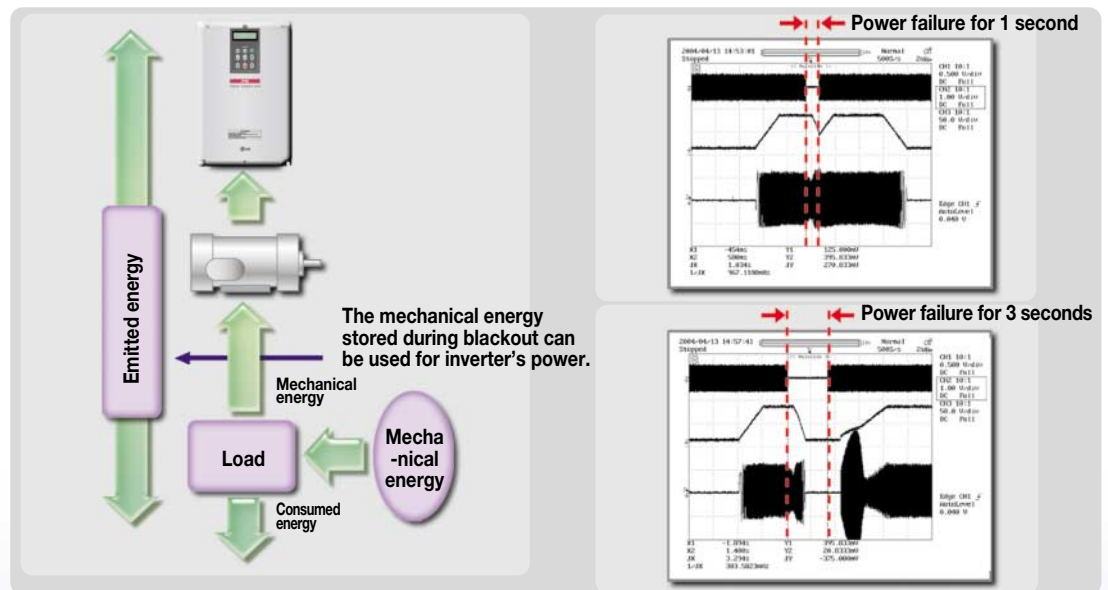

Safety Stop

When unexpected power-failure blocks power supply, inverter stops motor by using inertia energy of load that prevents unexpected second accident (Parameter setting is required).



Current Leakage Reduction Algorithm

Damp condition is subject to cause system failure due to current leakage. And iP5A invents LS PWM algorithm to blow out this danger.

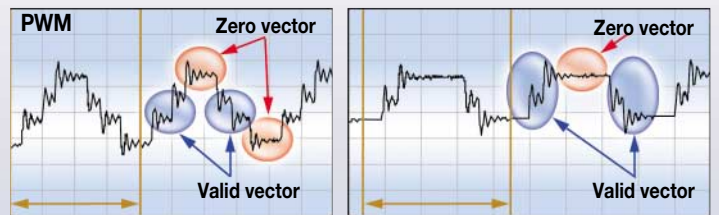

Flux Braking Algorithm

This can make the deceleration time shorter than the regular one, so it enhances system efficiency.



Automatic Carrier Frequency Change

Considering ambient temperature, iP5A can adjust the carrier frequency automatically.



Protection

iP5A has optimum optimal protection functions such as safety stop and prior motor operation.

User-friendly Keypad & Easy Maintenance

iP5A provides user-friendly keypad supporting simple parameter editing. And iP5A's frame work is created for easy maintenance.

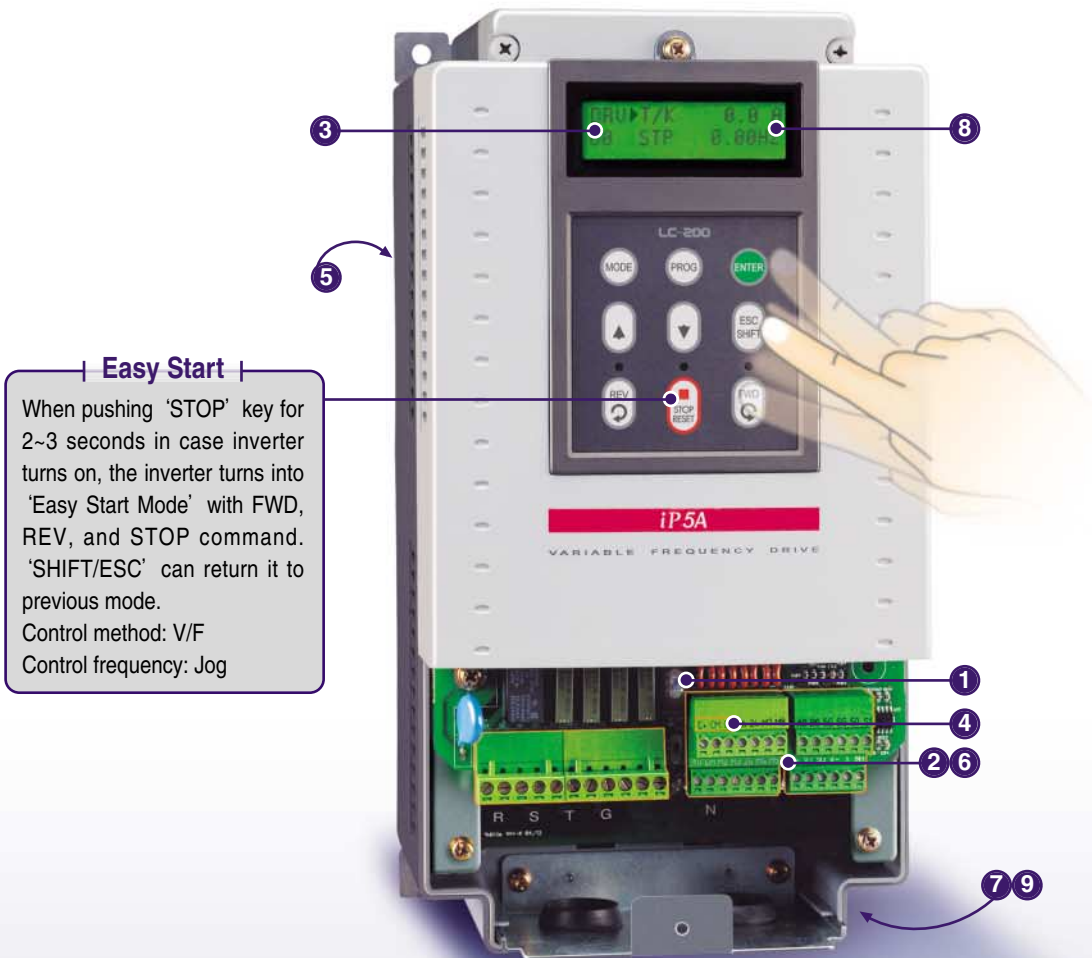

Easy Start

When pushing 'STOP' key for 2~3 seconds in case inverter turns on, the inverter turns into 'Easy Start Mode' with FWD, REV, and STOP command. 'SHIFT/ESC' can return it to previous mode.
Control method: V/F
Control frequency: Jog

1 NPN/PNP Input

iP5A has both NPN and PNP input, and you can select one of them easily.

2 Abundant I/O Suggestion

iP5A serves abundant I/O.

Digital Input/Output	8 points / 4 points
Analog Input (Voltage + Current)/Output	(1+1) points / 4 points
Pulse Input	1 point
NTC/PTC Input	1 point

3 Various Units of I/O Display

Various units of I/O display are supported in iP5A, so users can recognize operation status easily.

DRV_REF 500.0mBa
15 FBK 82.1mBa

DRV_REF 500.0kPa
15 FBK 82.1kPa

4 Built-in 485 and Optional Communication

Built-in 485 of iP5A enables to set up communication system by itself without any additional device. And optional communication suggestion of iP5A can satisfy users who want to construct their own system.

5 Long-life Condenser and Simple Framework

iP5A adopts long-life condenser and enables easy maintenance in simple framework.

6 Consumption Time Display

iP5A displays consumption time of components so that users can replace them in time.

7 Others

- Removable terminal board
- External fan available
- Cooling fan on/off control

Model & Type

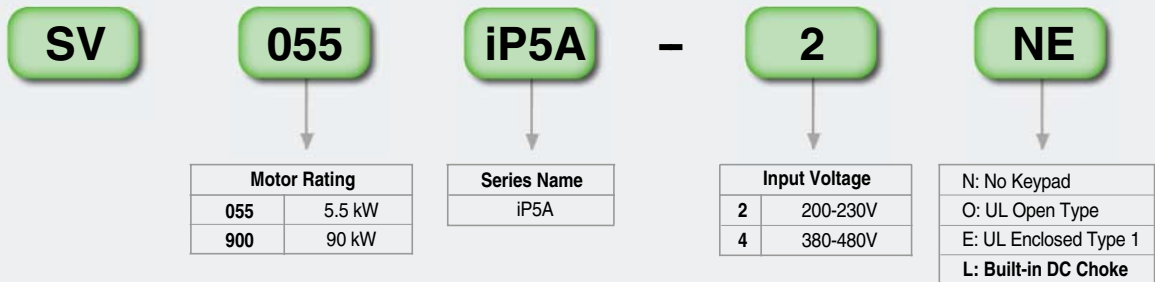

SV055iP5A-2NE

← Model Number

INPUT 200-230 V 3 Phase
25A 50/60HZ

← Input Rating

OUTPUT 0-Input V 3 Phase
24A 0.01-120HZ

← Output Rating

9.1KVA, Enclosed Type 1

← Protection Degree



← Bar Cord

92024000408

← Serial Number

LS Industrial Systems Co., Ltd. Made in Korea

Standard Specifications

●● 200~230V Class (5.5~30kW / 7.5~40HP)

Model Number (SV□□□ iP5A-2)		055	075	110	150	185	220	300		
Capacity [kVA] <small>Note1</small>		9.1	12.2	17.5	22.9	28.2	33.5	43.8		
Output ratings	Fan or pump load	Motor rating <small>Note2</small>	(HP)	7.5	10	15	20	25	30	40
			(kW)	5.5	7.5	11	15	18.5	22	30
		Current [A]	24	32	46	60	74	88	115	
	(110% over current) 110% 1 Minute (Normal Duty)									
	General load	Motor rating	(HP)	5.5	7.5	10	15	20	25	30
			(kW)	3.7	5.5	7.5	11	15	18.5	22
Current [A]		17	23	33	44	54	68	84		
(150% over current) 150% 1 Minute (Heavy Duty)										
Frequency		0.01~120 Hz								
Voltage		200~230V <small>Note3</small>								
Input ratings	Voltage	3 φ 200~230V (-15%~+10%)								
	Frequency	50/60 Hz (± 5%)								
Protection degree		IP20 / UL Type1				IP00 / UL Open <small>Note4</small>				
Weight [kg (lbs.)]		4.9 (10.8)	6 (13.2)	6 (13.2)	13 (28.7)	13.5 (29.8)	20 (44.1)	20 (44.1)		

●● 380~480V Class (5.5~90kW / 7.5~125HP)

Model Number (SV□□□ iP5A-4)		055	075	110	150	185	220	300	370	450	550	750	900		
Capacity [kVA] <small>Note1</small>		9.6	12.7	19.1	23.9	31.1	35.9	48.6	59.8	72.5	87.6	121.1	145.8		
Output ratings	Fan or pump load	Motor rating <small>Note2</small>	(HP)	7.5	10	15	20	25	30	40	50	60	75	100	125
			(kW)	5.5	7.5	11	15	18.5	22	30	37	45	55	75	90
		Current [A]	12	16	24	30	39	45	61	75	91	110	152	183	
	(110% over current) 110% 1 Minute (Normal Duty)														
	General load	Motor rating	(HP)	5.5	7.5	10	15	20	25	30	40	50	60	75	100
			(kW)	3.7	5.5	7.5	11	15	18.5	22	30	37	45	55	75
Current [A]		8.8	12	16	22/24	28/30	34/39	44/45	-	-	-	-	-		
(150% over current) 150% 1 Minute (Heavy Duty)															
Frequency		0.01~120 Hz													
Voltage		380~480V <small>Note3</small>													
Input ratings	Voltage	3 φ 380~480V (-15%~+10%)													
	Frequency	50/60 Hz (± 5%)													
Protection degree		IP20 / UL Type1				IP00 / UL Open <small>Note4</small>									
Weight [kg (lbs.)]	Standard Type	4.9 (10.8)	6 (13.2)	6 (13.2)	12.5 (27.6)	13 (28.7)	20 (44.1)	20 (44.1)	27 (59.5)	27 (59.5)	29 (64)	42 (92.6)	43 (94.8)		
	Built-in DCL Type	-	-	-	19.5 (43.9)	19.5 (42.9)	26.5 (58.3)	26.5 (58.3)	39 (86)	40 (88.2)	42 (92.6)	67 (147.4)	68 (149.9)		

●● 380~480V Class (110~450kW / 50~125HP)

Model Number (SV□□□ iP5A-4)		1100	1320	1600	2200	2800	3150	3750	4500		
Capacity [kVA] <small>Note1</small>		178	210	259	344	436	488	582	699		
Output ratings	Fan or pump load	Motor rating <small>Note2</small>	(HP)	150	200	250	300	350	400	500	600
			(kW)	110	132	160	220	280	315	375	450
		Current [A]	223	264	325	432	547	613	731	877	
	(110% over current) 110% 1 Minute (Normal Duty)										
	General load	Motor rating	(HP)	125	150	200	250	300	350	400	500
			(kW)	90	10	132	160	220	280	315	375
Current [A]		183	223	264	325	432	547	613	731		
(150% over current) 150% 1 Minute (Heavy Duty)											
Frequency		0.01~120 Hz									
Voltage		380~480V <small>Note3</small>									
Input ratings	Voltage	3 φ 380~480V (-15%~+10%)									
	Frequency	50/60 Hz (± 5%)									
Protection degree		IP00 / UL Open <small>Note4</small>									
DCL		Built-in				External Option					
Weight [kg (lbs.)]		101 (222.7)	101 (222.7)	114 (251.3)	200 (441.9)	200 (441.9)	243 (535.7)	380 (837.7)	380 (837.7)		

Note 1 Rated capacity (v 3 × V × I) is based on 220V for 200V class and 460V for 400V class.

Note 2 Indicates the maximum applicable capacity when using a 4-Pole LS motor.

Note 3 Maximum output voltage will not exceed the input voltage. An output voltage less than the input voltage may be programmed if necessary.

Note 4 IP20/UL Type1 with optional conduit, it can be modified to UL Type1.

Common Specifications

Cooling Method		Forced Cooling	
CONTROL	Control Method	V/F, Sensorless Vector, Slip Compensation, Easy Start Selectable	
	Frequency	Digital Reference: 0.01 Hz (Below 100 Hz), 0.1 Hz (Over 100 Hz)	
	Setting Resolution	Analog Reference: 0.01 Hz/60 Hz	
	Frequency Accuracy	Digital: 0.01% of Max. Output Frequency Analog: 0.1% of Max. Output Frequency	
	V/F Ratio	Linear, Squared Pattern, User V/F	
	Overload Capacity	110% per 1 min, 120% per 1 min ^{Note5)}	
	Torque Boost	Manual Torque Boost (0~15 % settable), Auto Torque Boost	
OPERATION	Operation Method	Keypad / Terminal / Communication Operation	
	Frequency Setting	Analog: 0~12V / -12V~12V / 4~20mA or 0~20mA / Pulse / Ext-PID Digital: Keypad	
	Input Signal	Start Signal	Forward, Reverse
		Multi-Step	Up to 18 Speeds can be set including Jog (Use Programmable Digital Input Terminal)
		Multi Step	0.1~ 6,000 sec, Max 4 types can be set via Multi-Function Terminal.
		Accel/Decel Time	Accel/Decel Pattern: Linear, U-Curve, S-Curve Selectable
		Emergency Stop	Interrupts the Output of Inverter
		Jog	Jog Operation
		Fault Reset	Trip Status is Reset when Protection Function is Active
	Output signal	Operating Status	Frequency Detection Level, Overload Alarm, Stalling, Over Voltage, Low Voltage, Inverter Overheating / Running / Stopping / Constant running, Inverter By-Pass, Speed Searching
		Fault Output	Contact Output (3A, 3C, 3B) – AC 250V 1A, DC 30V 1A
Indicator		Choose 2 from Output Frequency, Output Current, Output Voltage, DC Link Voltage (Output Voltage: 0~10V)	
Operation Function		DC Braking, Frequency Limit, Frequency Jump, 2nd Function, Slip Compensation, Reverse Rotation Prevention, Auto Restart, Inverter By-Pass, Auto-Tuning, PID Control, Flying Start, Safety Stop, Flux Braking, Low Leakage, Pre-PID, Dual-PID, MMC ^{Note6)} , Easy Start, Pre-heater	
DISPLAY PROTECTION	Inverter Trip	Over Voltage, Low Voltage, Over Current, Ground Fault, Inverter Overheat, Motor Overheat, Output Phase Open, Overload Protection, External Fault 1, 2, Communication Error, Loss of Speed Command, Hardware Fault, Option Fault etc	
	Inverter Alarm	Stall Prevention, Overload Alarm, Thermal Sensor Fault	
DISPLAY	Keypad	Operation Information	Output Frequency, Output Current, Output Voltage, Frequency Set Value, Operating Speed, DC Voltage, Integrating Wattmeter, Fan ON time, Runtime, Last Trip Time
		Trip Information	Trips Indication when the Protection Function activates. Max. 5 Faults are saved. Last Trip Time.
ENVIRONMENT	Ambient Temperature	-10°C ~40°C (14°F ~104°F) (Use loads less than 80% at 50°C)	
	Storage Temperature	-20°C ~65°C (14°F ~149°F)	
	Ambient Humidity	Less Than 90 % RH Max. (Non-Condensing)	
	Altitude – Vibration	Below 1,000m (3,300ft), Below 5.9m/sec ² (0.6g)	
	Application Site	Pollution degree 2, No Corrosive Gas, Combustible Gas, Oil Mist, or Dust	

Note 5) Overload rating 120%, 1 min is based on ambient 25°C.

6) MMC (Multi Motor Control) function is applied to drives for 5.5-90kW (7.5~125HP).

Wiring

⚡ For 5.5~30kW (7.5~40HP)

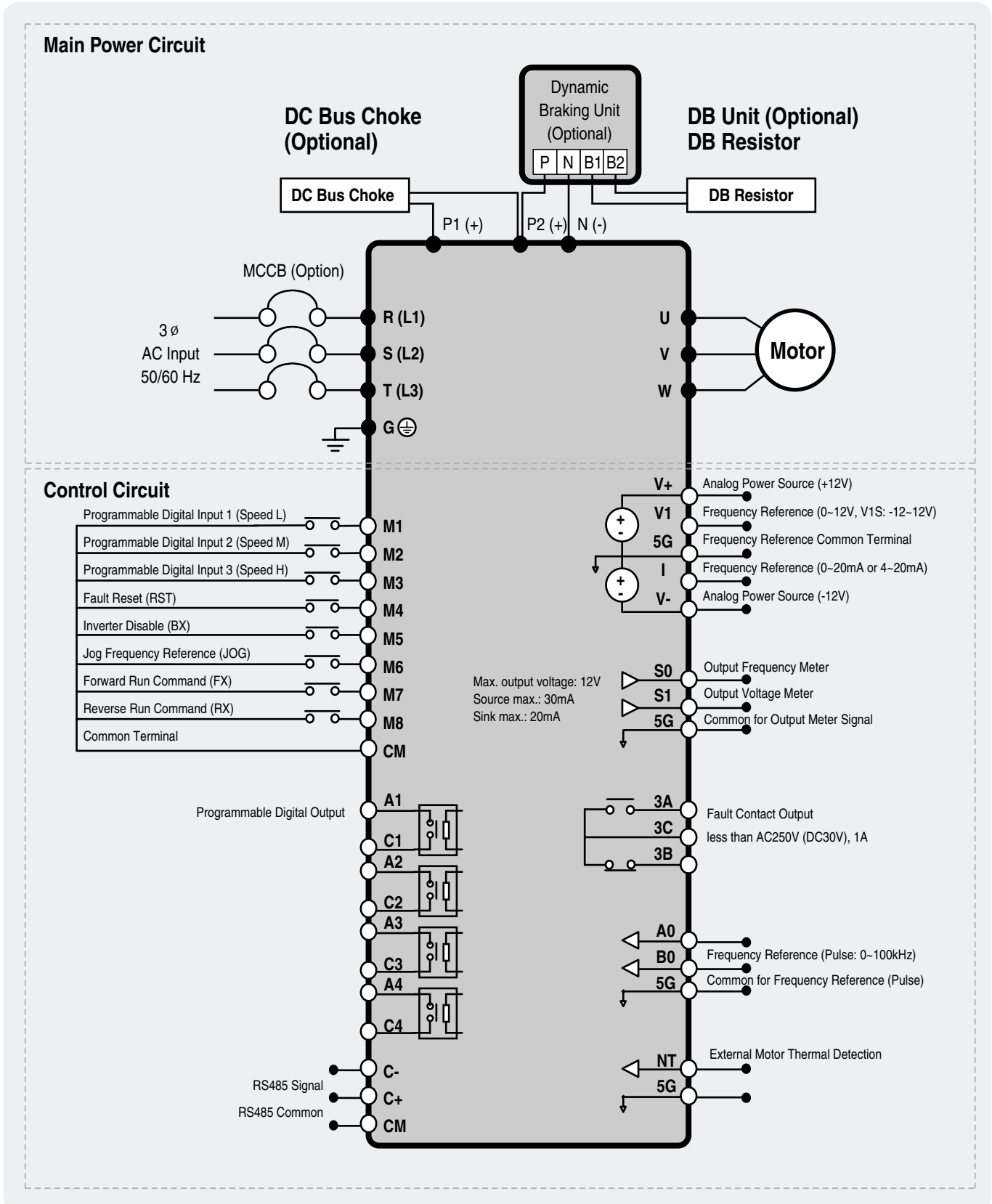

Note 1) 5G is Common Ground for Analog Input / Output.
2) Use terminal V1 for V1, V1S (0~12V, -12~12V) input.

For 37~90kW (50~125HP) / 315~450kW (400~600HP)

Main Power Circuit

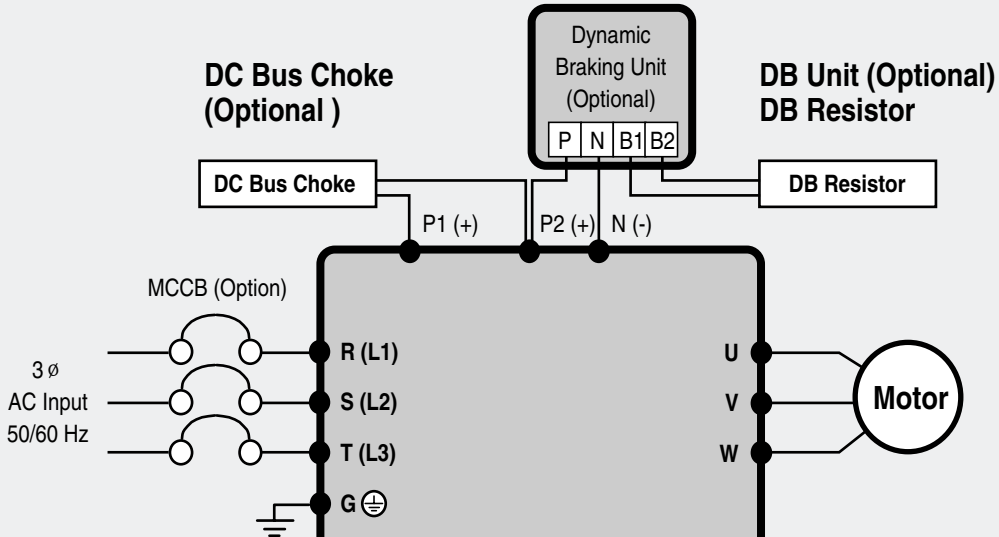

Control Circuit

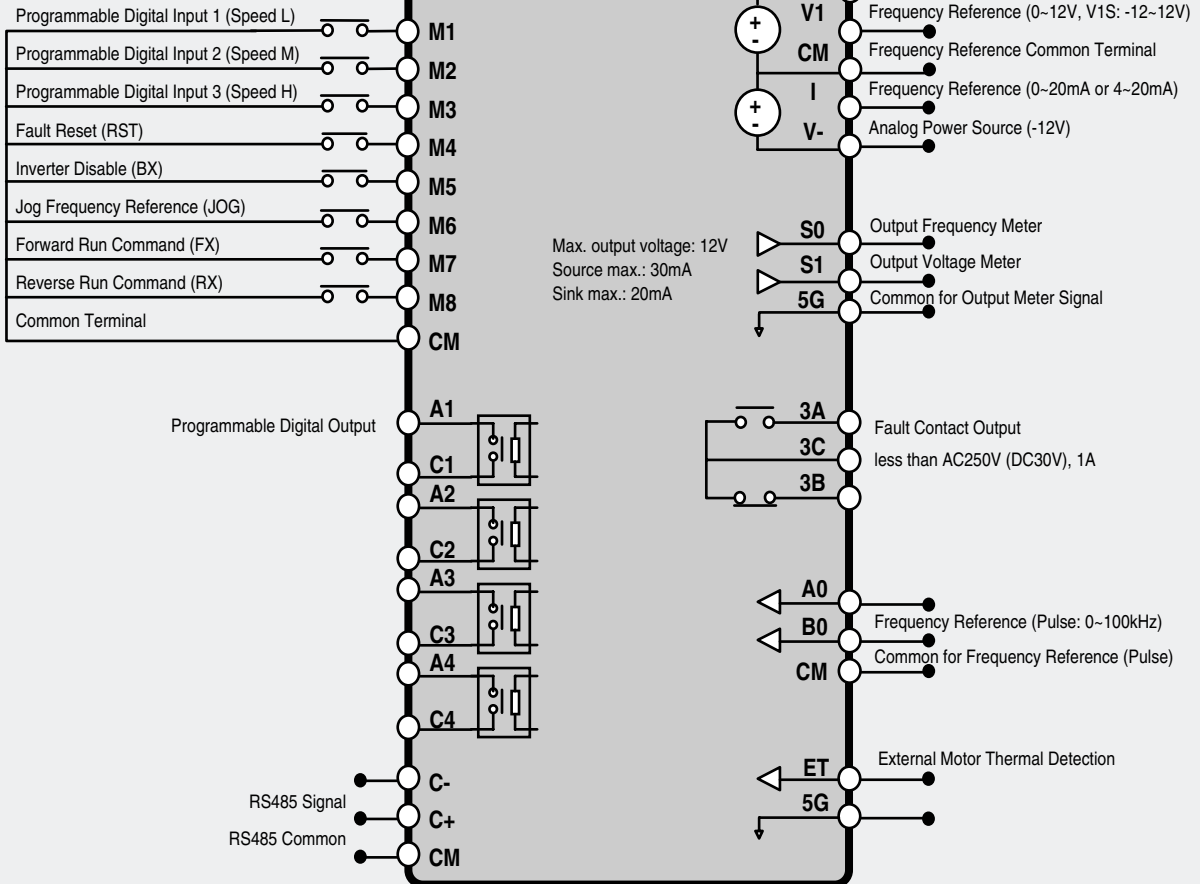

Note 1) 5G is Common Ground for Analog Meter Output (S0, S1) and External motor thermal detection (ET).
 2) Use terminal V1 for V1, V1S (0~12V, -12~-12V) input.
 3) DC Reactor is built basically in inverters for 15~280kW.

•• For 110~280kW (150~350HP)

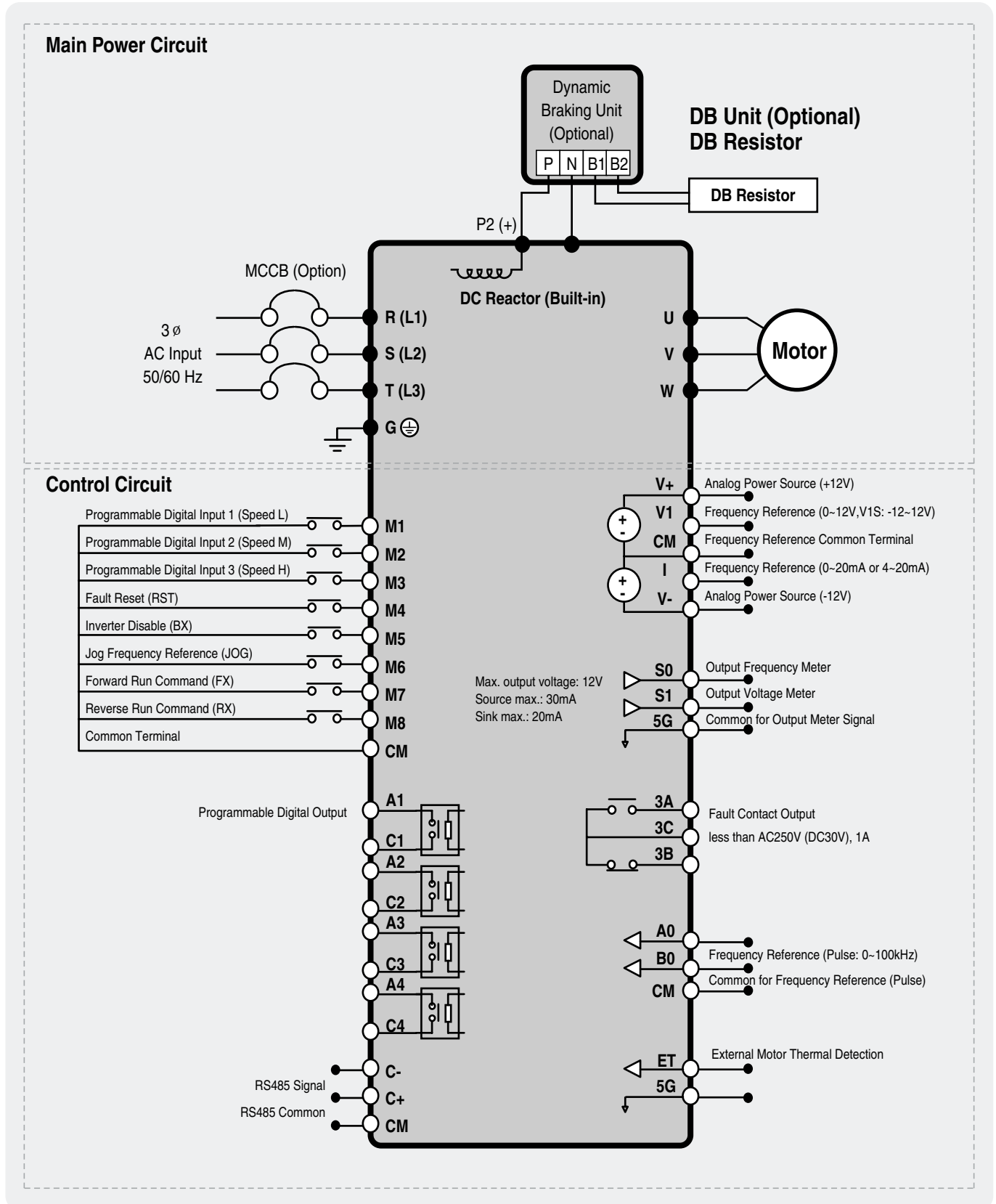

Note 1) 5G is Common Ground for Analog Meter Output (S0, S1) and External motor thermal detection (ET).
 2) Use terminal V1 for V1, V1S (0~12V, -12~12V) input.
 3) DC Reactor is built basically in inverters for 15~280kW.

•• For 15~30kW (20~40HP) Built-in DCL Type

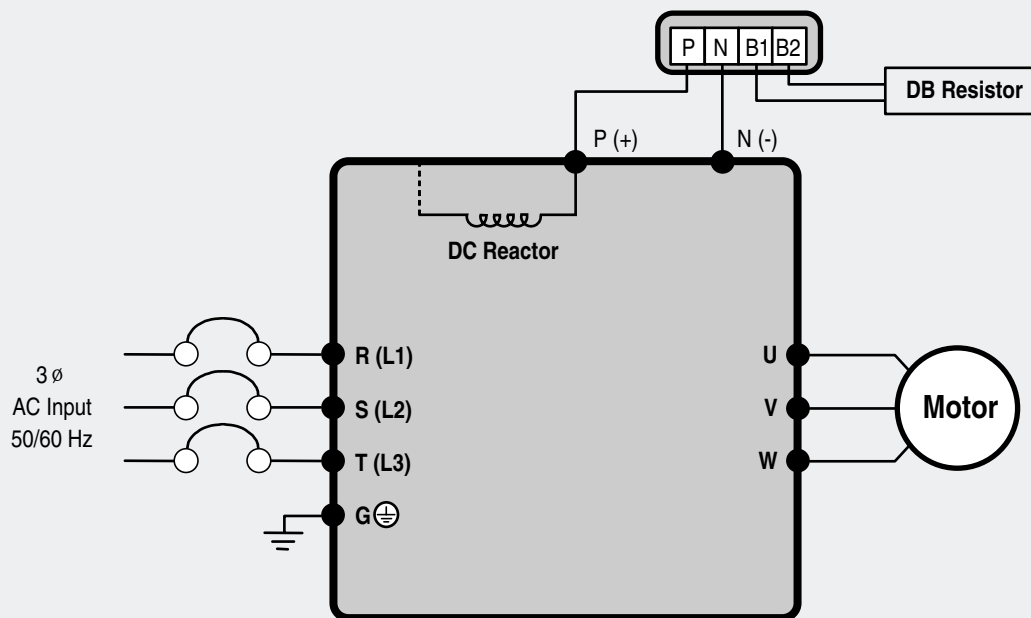

•• For 37~90kW (50~125HP) Built-in DCL Type

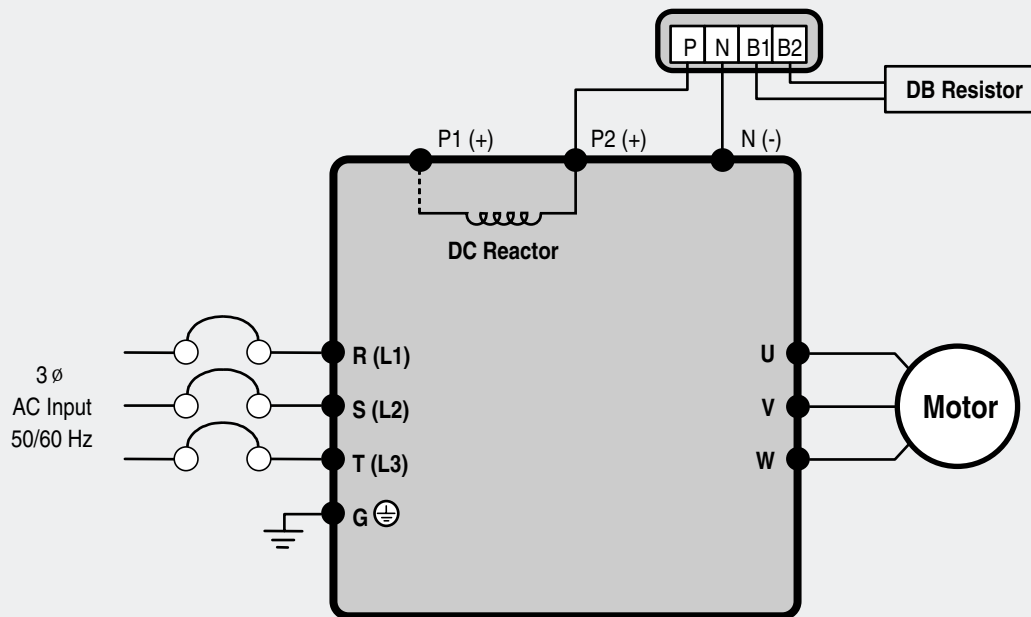

Note) P1 (+) is not provided for wiring.

Terminal Configurations (Power Circuit Terminal)

●● 5.5~30 kW (200V/400V Class)

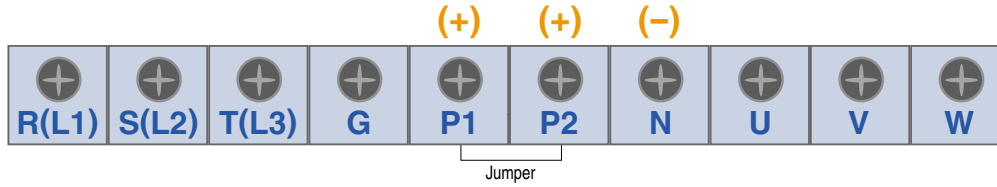

●● 37~90kW (50~125HP) / 315~450kW (400~600HP) <400V Class>

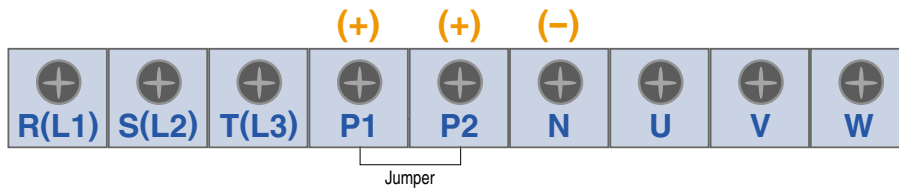

●● 15~18.5kW (20~25HP) <Built-in DC Reactor Type, 400V Class>

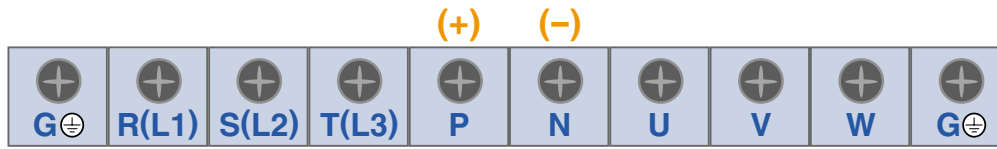

●● 22~30kW (30~40HP) <Built-in DC Reactor Type, 400V Class>

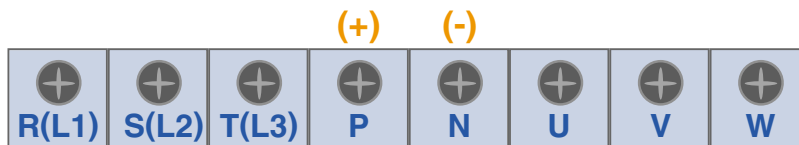

●● 37~90kW (50~125HP) / 110 ~280kW (150~350HP) <Built-in DC Reactor Type, 400V Class>

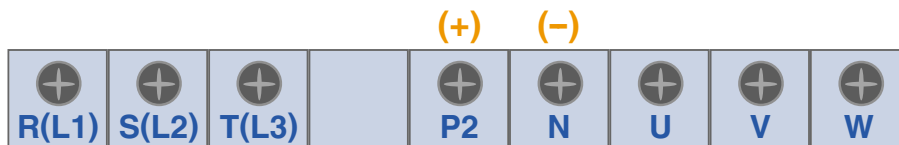

Note) P1 (+) is not provided for wiring.

Symbol	Description
R, S, T (L1, L2, L3)	AC Line Voltage Input
G	Earth Ground
P1 (+), P2 (+)	External DC Reactor [P1 (+)-P2 (+)] Connection Terminals (Jumper must be removed).
P2 (+), N (-) or P (+), N (-)	DB Unit [P2 (+)-N (-)] Connection Terminals
U, V, W	3 Phase Power Output Terminals to Motor

Terminal Configurations (Power Circuit Terminal)

Wires & Terminal lugs

Refer to below for wires, terminal lugs, and screws used to connect the inverter power input and output.

Inverter Capacity	Terminal Screw Size	Screw Torque		Wire				
				mm ²		AWG or kcmil		
		Kgf · cm	lb · in	R, S, T (L1, L2, L3)	U, V, W	R, S, T (L1, L2, L3)	U, V, W	
200V Class	5.5kW (7.5HP)	M4	17	15.2	5.5	5.5	10	10
	7.5kW (10HP)	M5	35	30.4	8	8	8	8
	11kW (15HP)	M5	35	30.4	14	14	6	6
	15kW (20HP)	M6	57	49.9	22	22	4	4
	18.5kW (25HP)	M6	57	49.9	38	38	2	2
	22kW (30HP)	M8	135	117.7	38	38	2	2
	30kW (40HP)	M8	135	117.7	60	60	1/0	1/0
400V Class	5.5kW (7.5HP)	M4	17	15.2	3.5	3.5	12	12
	7.5Kw (10HP)	M5	35	30.4	3.5	3.5	12	12
	11 kW (15HP)	M5	35	30.4	5.5	5.5	10	10
	15 kW (20HP)	M6	57	49.9	8	8	8	8
	18.5kW (25HP)	M6	57	49.9	14	14	6	6
	22~30kW (30~40HP)	M8	135	117.7	22	22	4	4
	37~55kW (50~75HP)	M8	135	117.7	38	38	2	2
	75~90kW (100~125HP)	M10	269	234.5	60	60	1/0	1/0
	110~132kW (150~200HP)	M12	474	412.4	100	100	4/0	4/0
	160kW (250HP)	M12	474	412.4	150	150	300	300
	220kW (300HP)	M12	474	412.4	200	200	400	400
	280kW (350HP)	M12	474	412.4	250	250	500	500
	315kW (400HP)	M12	474	412.4	325	325	700	700
	375kW (500HP)	M12	474	412.4	2 × 200	2 × 200	2 × 400	2 × 400
450kW (600HP)	M12	474	412.4	2 × 250	2 × 250	2 × 500	2 × 500	

Note) • Apply the rated torque to terminal screws.

- Loose screws can cause of short circuit or malfunction. Tightening the screw too much can damage the terminals and cause a short circuit or malfunction.
- Use copper wires only with 600V, 75°C ratings. For 7.5~11kW 240V type inverters, R (L1), S (L2), T (L3) and U, V, W terminals are only for use with insulated ring type connector.

Terminal Configurations (Control Circuit Terminal)

⚙️ 5.5~30kW/7.5~40HP (200V/400V Class)

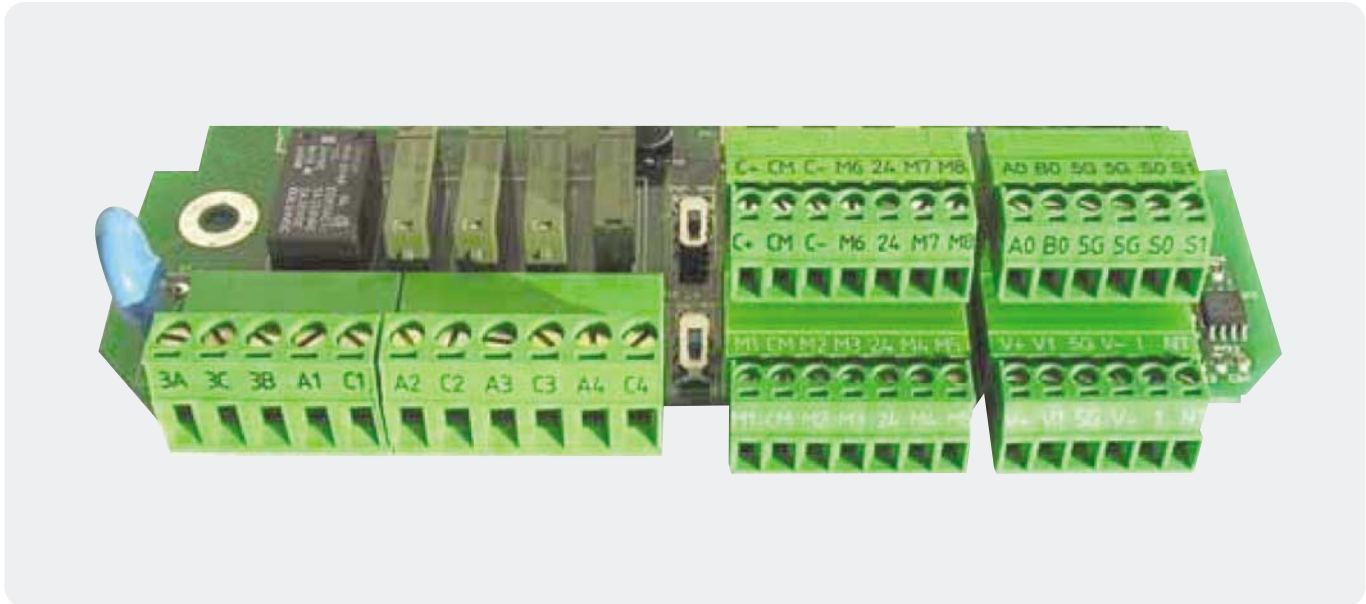

3A	3C	3B	A1	C1	A2	C2	A3	C3	A4	C4	C+	CM	C-	M6	24	M7	M8	A0	B0	5G	5P	S0	S1
											M1	CM	M2	M3	24	M4	M5	V+	V1	5G	V-	I	NT

⚙️ 37~450 kW/50~600HP (400V Class)

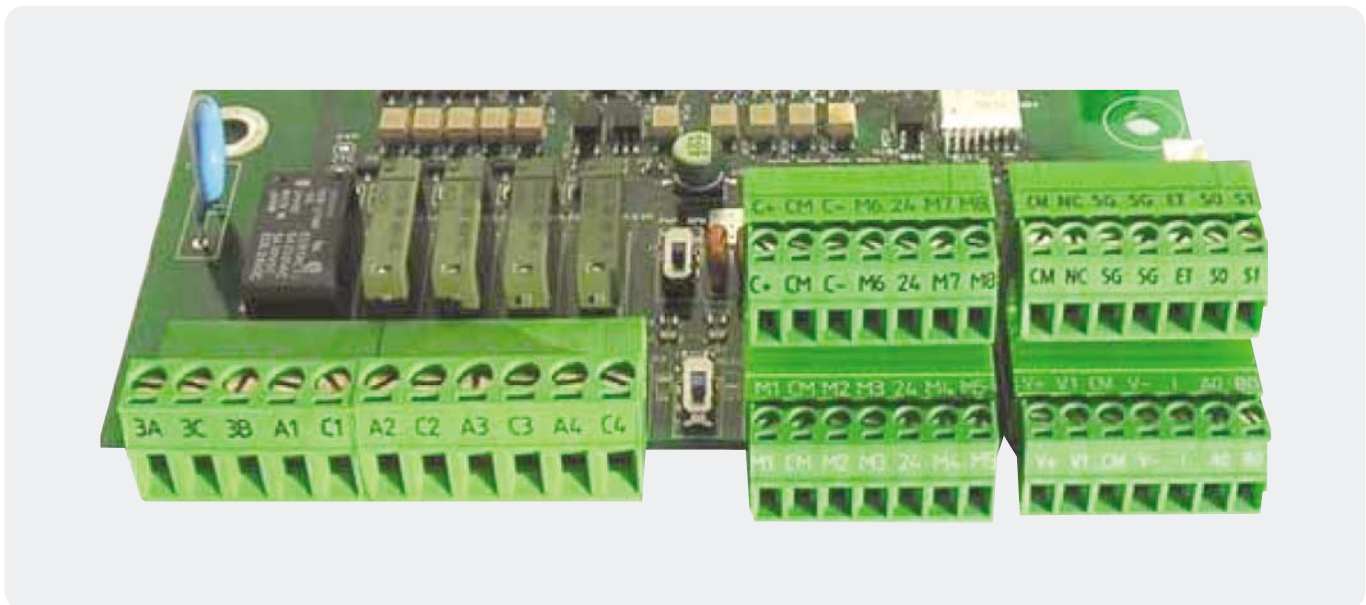

3A	3C	3B	A1	C1	A2	C2	A3	C3	A4	C4	C+	CM	C-	M6	24	M7	M8	CM	NC	5G	5G	ET	S0	S1
											M1	CM	M2	M3	24	M4	M5	V+	V1	CM	V-	I	A0	B0

Terminal Configurations (Control Circuit Terminal)

Type	Symbol	Name	Description	
Input Signal	Starting Contact Function Select	M1, M2, M3	Programmable Digital Input 1, 2, 3 Defines programmable digital inputs. (Factory setting: Multi-step frequency 1, 2, 3)	
		FX [M7]	Forward Run Command Forward run when closed and stopped when open.	
		RX [M8]	Reverse Run Command Reverse run when closed and stopped when open.	
		JOG [M6]	Jog Frequency Reference Runs at jog frequency when the jog signal is on. The direction is set by the FX (or RX) signal.	
		BX [M5]	Inverter Disable When the BX signal is ON, the output of the inverter is turned off. When motor uses an electrical brake to stop, BX is used to turn off the output signal. Take caution when BX signal is off (Not turned off by latching) and FX signal (or RX signal) is on. If so, motor continues to run.	
		RST [M4]	Fault Reset Used for fault reset.	
		CM	Sequence Common (NPN) / 24V Com. Common terminal for NPN contact input and also common for the external 24V supply.	
		24	Sequence Common (PNP) / Ext. +24Vdc supply Common 24V terminal for PNP contact input. Can be also used as a 24Vdc external power supply (Maximum output : +24V, 50mA)	
	Analog Frequency Setting	V+, V-	Analog Power Source (+12V, -12V) Power supply for analog frequency setting. Maximum output: +12V, 100mA, -12V, 100mA.	
		V1	Frequency Reference (Voltage) Used by a DC 0~12V or -12~12V input to set the frequency reference. (Input impedance is 20 k Ω)	
		I	Frequency Reference (Current) Used by a 0-20mA input to set the frequency reference. (Input impedance is 249 Ω)	
		A0, B0	Frequency Reference (Pulse) Used by a pulse input to set the frequency reference.	
		5G (~30kW) CM (37kW~)	Frequency Reference Common Terminal Common terminal for analog frequency reference signal.	
	External Motor Thermal Detection	NT (~30kW) ET (37kW~)	External Motor Thermal Detection Motor thermal sensor input. Used to prevent motor from overheating by using a NTC or PTC thermal sensor.	
		5G	Common for NT (or ET) Common terminal for external motor thermal detection.	
	RS485 Terminal	C+, C-	RS485 signal High, Low RS485 signal (See RS485 communication in manual for more details.)	
		CM	RS485 common Common ground. Terminal for RS485 interface.	
	Output Signal	Voltage	S0, S1, 5G Programmable Voltage Output Voltage output for one of the following: Output frequency, output current, output voltage, DC link voltage. Default is set to output frequency. (Maximum output voltage and output current are 0-12V and 1mA).	
		Contact	3A, 3C, 3B	Fault Contact Output Energizes when a fault is present. (AC250V, 1A: DC30V, 1A) Fault: 3A-3C closed (3B-3C Open) Normal: 3B-3C closed (3A-3C Open)
			A1~4, C1~4	Programmable Digital Output Defined by programmable digital output terminal settings (AC250V, 1A: DC30V, 1A)

Note) M1-M8 terminals are User Programmable.

Terminal Configurations (Control Circuit Terminal)

iP5A provides Sink/Source (NPN/PNP) modes for sequence input terminal on the control circuit. The logic of the input terminal is settable to Sink mode (NPN mode)/Source mode (NPN mode) by using the J1 switch.

Connection method is shown below.

Sink mode (NPN mode)

- Put J1 switch down to set to Sink mode (NPN mode). CM terminal (24V GND) is common terminal for contact signal input.
- The factory default is Sink mode (NPN mode).

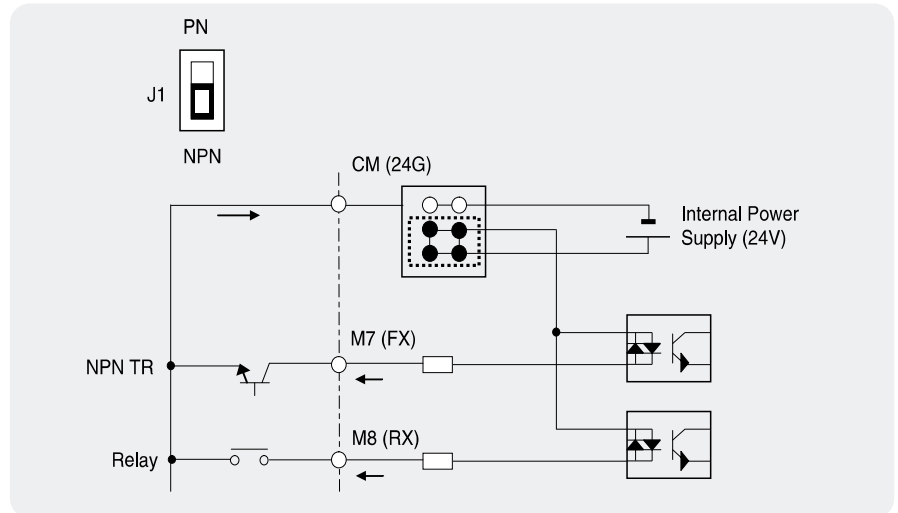

Source mode (PNP mode)

Internal Power Supply Used

- Put J1 switch up to set to Source mode (PNP mode). Terminal 24 (24V Power Supply) is common terminal for contact input signal.

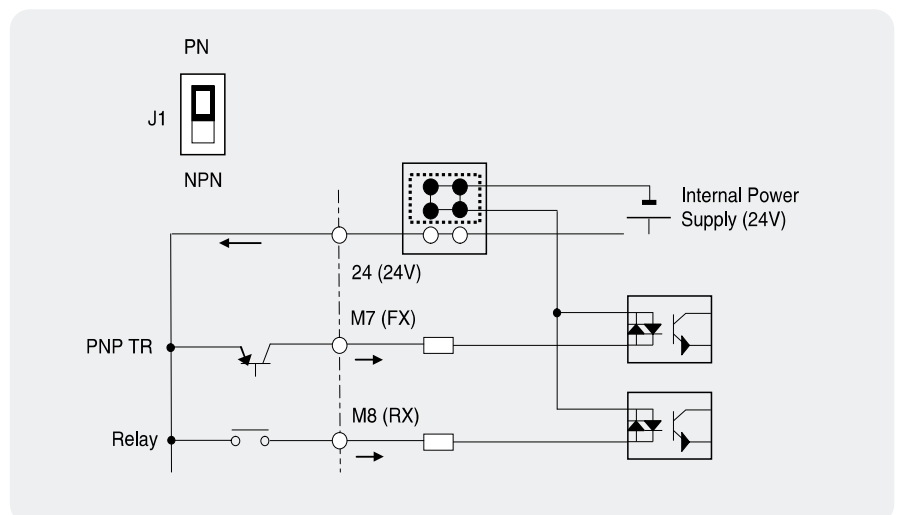

Source mode (PNP mode)

External Power Supply Used

- Put J1 switch up to set to Source mode (PNP mode).
- To use external 24V Power Supply, make a sequence between external Power Supply (-) terminal and CM (24V GND) terminal.

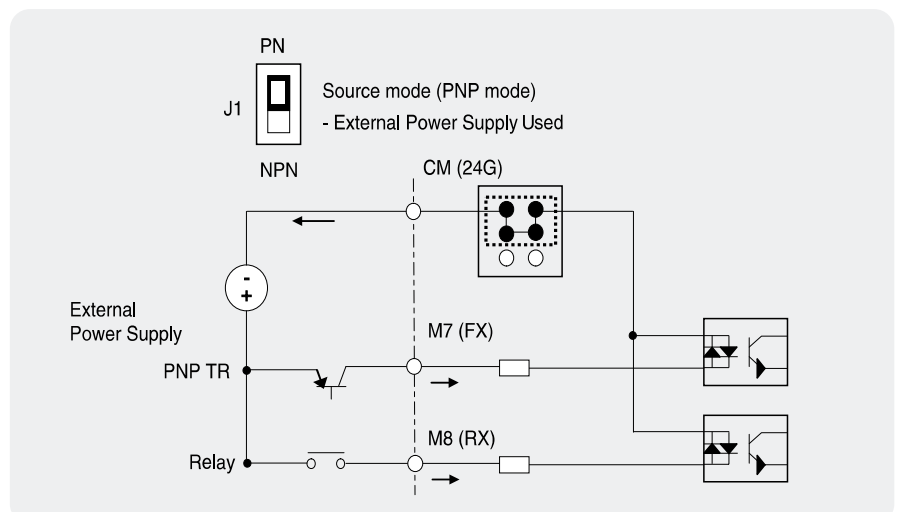

Programming Keypad

⚙️ LCD Loader

32 character, background light, LCD display. Background tone is adjustable.

Mode Button moves you through seven program groups:
 DRV [Mode]
 FUN1 [ENT] DRV

Reverse Run Button
 Reverse Run LED
 blinks when drive
 Accels or Decels.



Program Button is used to go into programming mode to change data.

Enter Button is used to enter changed data within a parameter.
 DRV [ENT] APP
 [MODE] DRV

[SHIFT] This button is used to move cursor across display in programming mode.
 [ESC] This button is used to move the program code to DRV 00 from any program code.

Forward Run Button
 Forward Run LED
 blinks when drive
 Accels or Decels.

Programming Keypad (Parameter Navigation)

⚙️ Parameter group moves directly to DRV group by pressing [SHIFT] key in any parameter code.

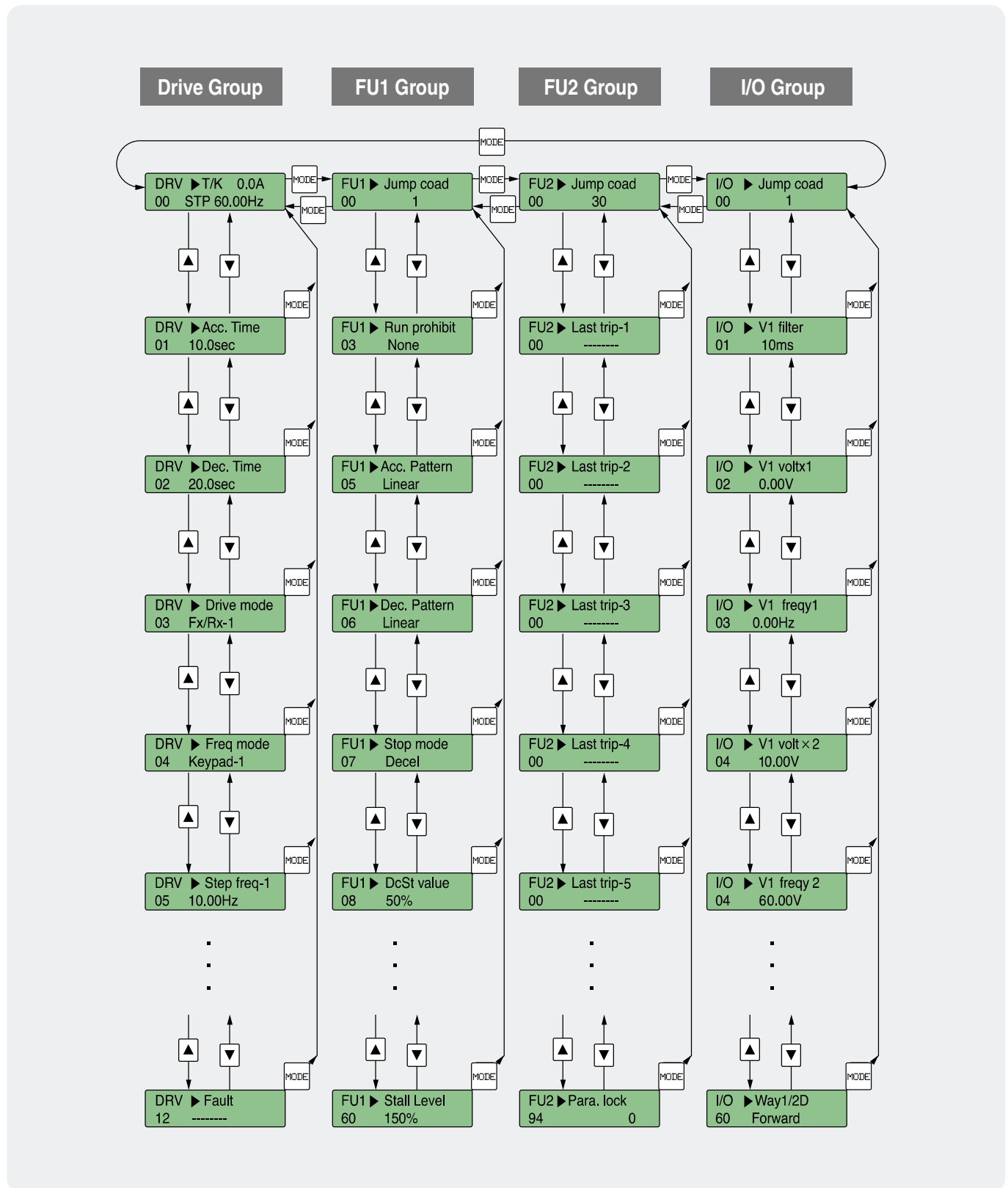

Note) This figure shows group and code navigation through LCD display keypad. It can be different from actual display due to the group addition or code change.

Parameter Description

DRV Group

CODE	Comm. Addr	Description	LCD Keypad Display	Setting Range	Factory Default	Adj. During Run
DRV-00 <small>Note1</small>	9100	Command Frequency (Output Frequency during motor run, Reference Frequency during motor stop), Output Current(LCD)	Cmd. Freq	0 to FU1-30 [Hz]	0 [Hz]	○
DRV-01	9101	Acceleration Time	5.5~90kW (7.5~125HP) 110~450kW (150~600HP)	0 to 6000 [sec]	20 [sec] 60 [sec]	○
DRV-02	9102	Deceleration Time	5.5~90kW (7.5~125HP) 110~450kW (150~600HP)	0 to 6000 [sec]	30 [sec] 90 [sec]	○
DRV-03	9103	Drive Mode (Run/Stop Method)	Drive Mode	0 (Keypad) 1 (Fx/Rx-1) 2 (Fx/Rx-2) 3 (Int. 485)	1 (Fx/Rx-1)	×
DRV-04	9104	Frequency Mode (Frequency setting method)	Freq Mode	0 (Keypad-1) 1 (Keypad-2) 2 (V1) 3 (V1S) 4 (I) 5 (V1+I) 6 (Pulse) 7 (Int. 485) 8 (Ext. PID)	0 (Keypad-1)	×
DRV-05	9105	Step Frequency 1	Step freq-1	0 to FU1-30 [Hz]	10 [Hz]	○
DRV-06	9106	Step Frequency 2	Step freq-2		20 [Hz]	○
DRV-07	9107	Step Frequency 3	Step freq-3		30 [Hz]	○
DRV-08	9108	Output Current	Current	* [A]	* [A]	*
DRV-09	9109	Motor Speed	Speed	* [rpm]	* [rpm]	*
DRV-10	910A	DC link Voltage	DC link Vtg	* [V]	* [V]	*
DRV-11	910B	User Display Selection	User disp		Output voltage [V]	*
DRV-12	910C	Current Trip Display	Fault	*	*	*
DRV-13	910D	Motor Direction	Use Only 7-Segment Keypad	0 (Forward)/1 (Reverse)	0	○
DRV-14 <small>Note2</small>	910E	Target/Output Frequency Display	Tar. Out. Freq.	* [Hz]	* [Hz]	*
DRV-15 <small>Note2</small>	910F	Reference/Feedback Frequency Display	Ref. Fbk. Freq.	* [Hz]	* [Hz]	*
DRV-16	9110	Speed Unit Selection	Hz/Rpm Disp	Hz or Rpm	[Hz]	○
DRV-18 <small>Note2</small>	9112	PID Parameter	Pid Parameter	* [Hz]	* [Hz]	×
DRV-19	9113	AD Parameter	AD Parameter	AD	AD	×
DRV-20 <small>Note3</small>	9114	EXT-PID Parameter	Ext Pid Para	[%]	%	×
DRV-91 <small>Note4</small>	915B	Drive Mode 2	Drive Mode2	0 (Keypad) 1 (Fx/Rx-1) 2 (Fx/Rx-2)	1 (Fx/Rx-1)	×
DRV-92 <small>Note4</small>	915C	Frequency Mode 2	Freq Mode2	0 (Keypad-1) 1 (Keypad-2) 2 (V1) 3 (V1S) 4 (I) 5 (V1+I) 6 (Pulse)	0 (Keypad-1)	×

 The gray-highlighted codes are hidden parameters and will appear when the related functions are to be set.

Note 1) The speed unit is changed from [Hz] to [%] when DRV-16 is set to [Rpm]. Only User Unit will be displayed when APP-02 is set to [Yes] and when APP-06 is set to either I, V1 or Pulse and when one of I/O-86- I/O-88 is set to either [Speed], [Percent], [Bar], [mBar], [kPa] or [Pa].

Output Frequency is displayed in DRV-00 during the Inverter is running. User Unit reference is displayed in DRV-00 during the Inverter is not running.

2) DRV-15, DRV-18 will appear when APP-02 [Process PI Mode] is set to "Yes". Also User Unit is displayed when one of I/O-86-I/O-88 is set to either [Speed], [Percent], [Bar], [mBar], [kPa] or [Pa].

3) DRV-20 will appear when APP-80 [Ext Process PI Mode] is set to "Yes".

4) DRV-91/92 will appear only when one of I/O-20~27 is set to [Main drv] and DRV- 03/04 is set to [int485].

●● FU1 GROUP

CODE	Comm. Addr	Description	LCD Keypad Display	Setting Range	Factory Default	Adj. During Run	
FU1-00	9200	Jump to Desired Code #	Jump Code	1 to 74 (Use Only LCD Keypad)	1	○	
FU1-01	9201	Run Prevention	Run Prevention	0	(None)	0 (None)	×
				1	(Fwd prev)		
				2	(Rev prev)		
FU1-02	9202	Acceleration Pattern	Acc. Pattern	0	(Linear)	0 (Linear)	×
				1	(S-curve)		
				2	(U-curve)		
FU1-03	9203	Deceleration Pattern	Dec. Pattern	0	(Linear)	0 (Linear)	×
				1	(S-curve)		
				2	(U-curve)		
FU1-04	9204	Start Curve for S-Curve Accel/Decel Pattern	Start Curve	0 to 100 [%]	50 [%]	×	
FU1-05	9205	End Curve for S-Curve Accel/Decel Pattern	End Curve	0 to 100 [%]	50 [%]	×	
FU1-10	920A	Pre-Heat	Pre-Heat Mode	0	(No)	0 (No)	×
				1	(Yes)		
FU1-11	920B	Pre-Heat Value	Pre Heat Level	1 to 50 [%]	30 [%]	×	
FU1-12	920C	Pre-Heat Duty	Pre Heat Perc	1 to 100 [%]	100 [%]	×	
FU1-20	9214	Start Mode	Start Mode	0	(Accel)	0 (Accel)	×
				1	(Dc-start)		
				2	(Flying-start)		
FU1-21	9115	Starting DC Injection Braking Time	DcSt Time	0 to 60 [sec]	0 [sec]	×	
FU1-22	9116	Starting DC Injection Braking Value	DcSt Value	0 to 150 [%]	50 [%]	×	
FU1-23	9217	Stop Mode	Stop Mode	0	(Decel)	0 (Decel)	×
				1	(Dc-brake)		
				2	(Free-run)		
				3	(Flux-brake)		
FU1-24	9218	DC Injection Braking On-delay Time	DcBlk Time	0.1 to 60 [sec]	0.1 [sec]	×	
FU1-25	9219	DC Injection Braking Frequency	DcBr Freq	0.1 to 60 [Hz]	5 [Hz]	×	
FU1-26	921A	DC Injection Braking Time	DcBr Fime	0 to 60 [sec]	1 [sec]	×	
FU1-27	921B	DC Injection Braking Value	DcBr Value	0 to 200 [%]	50 [%]	×	
FU1-28	921C	Safety Stop	Safety Stop	0	(No)	0 (No)	×
				1	(Yes)		
FU1-29	921D	Power Source Freq	Line Freq	40 to 120 [Hz]	60 [Hz]	×	
FU1-30	921E	Maximum Frequency	Max Treq	40 to 120 [Hz]	60 [Hz]	×	
FU1-31	921F	Base Frequency	Base Treq	30 to 120 [Hz]	60 [Hz]	×	
FU1-32	9220	Starting Frequency	Start Treq	0.1 to 10 [Hz]	0.5 [Hz]	×	
FU1-33	9221	Frequency Limit Selection	Freq Limit	0	(No)	0 (No)	×
				1	(Yes)		
FU1-34	9222	Low Limit Frequency	F-limit Lo	0 to FU1-35	0.5 [Hz]	○	
FU1-35	9223	High Limit Frequency	F-limit Hi	FU1-34 to FU1-30	60 [Hz]	×	

□ The gray-highlighted codes are hidden parameters and will appear when the related functions are to be set.

Note 5) Only displayed when FU1-02, FU1-03 is set to [S-Curve].

6) Only displayed when FU1-20 is set to [DC-start].

7) Only displayed when FU1-23 is set to [DC-break].

8) Only displayed when FU1-33 is set to "Yes".

Parameter Description

❖ FU1 GROUP

CODE	Comm. Addr	Description	LCD Keypad Display	Setting Range	Factory Default	Adj. During Run	
FU1-40	9228	Volts/Hz Pattern	V/F Pattern	0	(Linear)	0 (Linear)	×
				1	(Square)		
				2	(User V/F)		
FU1-41 <small>Note9)</small>	9229	User V/F – Frequency 1	User Freq 1	0 to FU1-30	15 [Hz]	×	
FU1-42	922A	User V/F – Voltage 1	User Volt 1	0 to 100 [%]	25 [%]	×	
FU1-43	922B	User V/F – Frequency 2	User Freq 2	0 to FU1-30	30 [Hz]	×	
FU1-44	922C	User V/F – Voltage 2	User Volt 2	0 to 100 [%]	50 [%]	×	
FU1-45	922D	User V/F – Frequency 3	User Freq 3	0 to FU1-30	45 [Hz]	×	
FU1-46	922E	User V/F – Voltage 3	User Volt 3	0 to 100 [%]	75 [%]	×	
FU1-47	922F	User V/F – Frequency 4	User Freq 4	0 to FU1-30	60 [Hz]	×	
FU1-48	9230	User V/F – Voltage 4	User Volt 4	0 to 100 [%]	100 [%]	×	
FU1-49	9231	Input Voltage Adjustment	VAC 440.0V	73 to 115.0 [%]	100.0 [%]	×	
FU1-50	9232	Motor Rated Voltage	Motor Volt	0 to 600 [V]	0 [V]	×	
FU1-51	9233	Energy Save	Energy Save	0	(None)	0 (None)	×
				1	(Manual)		
				2	(Auto)		
FU1-52 <small>Note10)</small>	9234	Energy Save %	Manual Save %	0 to 30 [%]	0 [%]	○	
FU1-54	9236	Integrating Wattmeter	Kilo Watt Hour	M kWh	*	×	
FU1-55	9237	Inverter Temperature	Inv. Temp.	0 to 160 [Degree]	*	×	
FU1-56	9238	Motor Temperature	Motor Temp.	0 to 160 [Degree]	*	×	
FU1-57	9239	No Motor Selection	No Motor Sel	0	(No)	1 [Yes]	×
				1	(Yes)		
FU1-58	923A	Trip Current Level	No Motor Level	5 to 100 [%]	5 [%]	×	
FU1-59	923B	Trip Time Setting	No Motor Time	0.5 to 10.0 [sec]	3.0 [sec]	×	
FU1-60	923C	Electronic Thermal Selection	ETH Select	0	(No)	1 (Yes)	○
				1	(Yes)		
FU1-61	923D	Electronic Thermal Level for 1 Minute	ETH 1min	FU1-62 to 200 [%]	150 [%]	○	
FU1-62	923E	Electronic Thermal Level for Continuous	ETH Cont	50 to FU1-61 (Maximum 150%)	120 [%]	○	
FU1-63	923F	Characteristic Selection (Motor Type)	Motor Type	0	(Self-cool)	0 (Selfcool)	○
				1	(Forced-cool)		
FU1-64	9240	Overload Warning Level	OL Level	30 to 110 [%]	110 [%]	○	
FU1-65	9241	Overload Warning Time	OL Time	0 to 30 [sec]	10 [sec]	○	
FU1-66	9242	Overload Trip Selection	OLT Select	0	(No)	0 (No)	○
				1	(Yes)		
FU1-67 <small>Note11)</small>	9243	Overload Trip Level	OLT Level	30 to 150 [%]	120 [%]	○	
FU1-68	9244	Overload Trip Delay Time	OLT Time	0 to 60 [sec]	60 [sec]	○	
FU1-69	9245	Input/Output Phase Loss Protection	Trip Select	000 to 111 (Bit Set)	100	○	
FU1-70	9246	Stall Prevention Mode Selection	Stall Prev.	000 to 111 (Bit)	000 (Bit)	×	
FU1-71	9247	Stall Prevention Level	Stall Level	30 to 150 [%]	100 [%]	×	
FU1-72	9248	Accel/Decel Change Frequency	Acc/Dec Ch F	0 to FU1-30	0 [Hz]	×	
FU1-73	9249	Reference Frequency for Accel and Decel	Acc/Dec Freq	0	(Max freq)	0 (Max freq)	×
				1	(Delta freq)		
FU1-74	924A	Accel/Decel Time Scale	Time Scale	0	(0.01 sec)	1 (0.1 sec)	○

 The gray-highlighted codes are hidden parameters and will appear when the related functions are to be set.

Note 9) FU1-41~48 only displayed when FU1-40 is set to 'User V/F'.

10) Only displayed when FU1-51 is set to 'Manual'.

11) Only displayed when FU1-66 is set to 'Yes'.

FU2 GROUP

CODE	Comm. Addr	Description	LCD Keypad Display	Setting Range	Factory Default	Adj. During Run
FU2-00	9300	Jump to Desired Code #	Jump Code	1 to 95 (Use Only LCD Keypad)	40	○
FU2-01	9301	Last Trip 1	Last Trip-1	By pressing [PROG] and [▲] key, the frequency, current, and operational status at the time of fault can be seen.	0 (None)	*
FU2-02	9302	Last Trip 2	Last Trip-2		0 (None)	*
FU2-03	9303	Last Trip 3	Last Trip-3		0 (None)	*
FU2-04	9304	Last Trip 4	Last Trip-4		0 (None)	*
FU2-05	9305	Last Trip 5	Last Trip-5		0 (None)	*
FU2-06	9306	Erase Trips	Erase Trips	0 (No) 1 (Yes)	0 (No)	○
FU2-07	9307	Dwell Frequency	Dwell Time	0 to 10 [sec]	0 [sec]	×
FU2-08 <small>Note12</small>	9308	Dwell Frequency	Dwell Freq	FU1-32 to FU1-30	5 [Hz]	×
FU2-10	930A	Frequency Jump Selection	Jump Freq	0 (No) 1 (Yes)	0 (No)	×
FU2-11 <small>Note13</small>	930B	Jump Frequency 1	Low Jump Lo 1	0 to FU2-12	10 [Hz]	○
FU2-12	930C	Jump Frequency 1	High Jump Hi 1	FU2-11 to FU1-30	15 [Hz]	○
FU2-13	930D	Jump Frequency 2	Low Jump Lo 2	0 to FU2-14	20 [Hz]	○
FU2-14	930E	Jump Frequency 2	High Jump Hi 2	FU2-13 to FU1-30	25 [Hz]	○
FU2-15	930F	Jump Frequency 3	Low Jump Lo 3	0 to FU2-16	30 [Hz]	○
FU2-16	9310	Jump Frequency 3	High Jump Hi 3	FU2-15 to FU1-30	35 [Hz]	○
FU2-20	9314	Power ON Start Selection	Power-ON Run	0 (No) 1 (Yes)	0 (No)	○
FU2-21	9315	Restart after Fault Reset	RST Restart	0 (No) 1 (Yes)	0 (No)	○
FU2-22	9316	Speed Search Selection	Speed Search	0000 to 1111 (Bit Set)	0000	×
FU2-23 <small>Note14</small>	9317	P Gain During Speed Search	SS P-Gain	0 to 9999	200	○
FU2-24	9318	I Gain During Speed Search	SS I-Gain	0 to 9999	500	○
FU2-25	9319	Number of Auto Retry	Retry Number	0 to 10	0	○
FU2-26 <small>Note15</small>	931A	Delay Time before Auto Retry	Retry Delay	0 to 60 [sec]	1 [sec]	○
FU2-40	9328	Rated Motor Selection for 5.5~450kW Inverter	Motor Select	0 (0.75kW) 1 (1.5kW) 2 (2.2kW) 3 (3.7kW) 4 (5.5kW) 5 (7.5kW) 6 (11.0kW) 7 (15.0kW) 8 (18.5kW) 9 (22.0kW) 10 (30.0kW) 11 (37.0kW) 12 (45.0kW) 13 (55.0kW) 14 (75.0kW) 15 (90.0kW) 16 (110.0kW) 17 (132.0kW) 18 (160.0kW) 18 (220.0kW) 20 (280.0kW) 21 (315.0kW) 22 (375.0kW) 23 (450.0kW)	*Depending on the inverter capacity	×
FU2-41	9329	Number of Motor Poles	Pole Number	2 to 12	4	×
FU2-42	932A	Rated Motor Slip	Rated-Slip	0 to 10 [Hz]		×
FU2-43	932B	Rated Motor Current (RMS)	Rated-Curr	1 to 200 [A]	*Depending on FU2-40	×
FU2-44	932C	No Load Motor Current (RMS)	Noload-Curr	0.5 to 200 [A]		×
FU2-45	932D	Motor Efficiency	Efficiency	70 to 100 [%]		×

□ The gray-highlighted codes are hidden parameters and will appear when the related functions are to be set.

Note 12) Only displayed when FU2-07 is set to [1~10 sec].

13) Only displayed when FU2-10 is set to 'Yes'.

14) Only displayed when FU1-23 is set to [DC-break].

15) Only displayed when FU1-33 is set to "Yes".



●● FU2 GROUP

CODE	Comm. Addr	Description	LCD Keypad Display	Setting Range	Factory Default	Adj. During Run	
FU2-46	932E	Load Inertia	Inertia Rate	0 to 8	0	×	
FU2-47	932F	Gain for Motor Speed Display	RPM Factor	1 to 1000 [%]	100 [%]	○	
FU2-48	9330	Carrier Frequency	Carrier Freq	5.5~22kW	0.7~15 [kHz]	5 [kHz]	○
				30kW	0.7~10 [kHz]		
				37~75kW	0.7~4 [kHz]	4 [kHz]	
				90~450kW	0.7~3 [kHz]	3 [kHz]	
FU2-49	9331	PWM Type Selection	PWM Mode	0	(Normal 1)	0 (Normal 1)	×
				1	(Normal 2)		
				2	(Low leakage)		
FU2-60	933C	Control Mode Selection	Control Mode	0	(V/F)	0 (V/F)	×
				1	(Slip compen)		
				2	(Sensorless)		
FU2-61	933D	Auto Tuning Selection	Auto Tuning	0	(No)	0 (No)	×
				1	(Yes)		
FU2-62	933E	Stator Resistance of Motor	Rs	0 to (depending on FU2-40) [ohm]	*Depending on FU2-40	×	
FU2-63	933F	Leakage Inductance of Motor	Lsigma	0 to (depending on FU2-40) [mH]	*Depending on FU2-40	×	
* Automatically set corresponding to motor rating. If different, check motor rating setting.							
FU2-64	9340	Pre-excitation Time	Pre Ex Time	0 to 60 [sec]	1 [sec]	×	
FU2-65	9341	P Gain for Sensorless Control	SL P-Gain	0 to 9999	1000	○	
FU2-66	9342	I Gain for Sensorless Control	SL I-Gain	0 to 9999	100	○	
FU2-67	9343	Manual/Auto Torque Boost Selection	Torque Boost	0	(Manual)	0 (Manual)	×
				1	(Auto)		
FU2-68	9344	Torque Boost in Forward Direction	Fwd Boost	0 to 15 [%]	2 [%]	×	
FU2-69	9345	Torque Boost in Reverse Direction	Rev Boost	0 to 15 [%]	2 [%]	×	
FU2-80	9350	Power On Display	Power On Disp	0 to 12	0	○	
FU2-81	9351	User Display Selection	User Disp	1	(Watt)	0 (Voltage)	○
				0	(Voltage)		
FU2-82	9352	Software Version	S/W Version	Ver X.XX	Ver X.XX	*	
FU2-83	9353	Last Trip Time	Last Trip Time	X:XX:XX:XX:XX:X		×	
FU2-84	9354	Power On Time	On-Time	X:XX:XX:XX:XX:X		×	
FU2-85	9355	Run-time	Run-Time	X:XX:XX:XX:XX:X		×	
FU2-87	9357	Power Set	Power Set	0.1~400 [%]	100	○	
FU2-90	935A	Parameter Display	Para. Disp	0	(Default)	0 (Default)	×
				1	(All Para)		
				2	(Diff Para)		
FU2-91	935B	Read Parameter	Para. Read	0	(No)	0 (No)	×
				1	(Yes)		
FU2-92	935C	Write Parameter	Para. Write	0	(No)	0 (No)	×
				1	(Yes)		
FU2-93	935D	Initialize Parameter	Para. Init	0	(No)	0 (No)	×
				1	(All Groups)		
				2	(DRV)		
				3	(FU1)		
				4	(FU2)		
				5	(I/O)		
				6	(EXT)		
				7	(COM)		
8	(APP)						
FU2-94	935E	Parameter Write Protection	Para. Lock	0 to 9999	0	○	
FU2-95	935F	Parameter Save	Para. Save	0	(No)	0 (No)	×
				1	(Yes)		

□ The gray-highlighted codes are hidden parameters and will appear when the related functions are to be set.

Note 16) FU1-41~48 only displayed when FU1-40 is set to "User V/F."

I/O GROUP

CODE	Comm. Addr	Description	LCD Keypad Display	Setting Range	Factory Default	Adj. During Run
I/O-00	9400	Jump to Desired Code #	Jump Code	1 to 98 (LCD Keypad Only)	1	○
I/O-01 <small>Note17)</small>	9401	Filtering Time Constant for V1 Signal Input	V1 Filter	0 to 9999 [msec]	10 [msec]	○
I/O-02	9402	V1 Input Minimum Voltage	V1 Volt x1	0 to 12 [V]	0 [V]	○
I/O-03	9403	Frequency Corresponding to V1 Input Minimum Voltage	V1 Freq y1	0 to FU1-30 [Hz] 0 to 100.00 [**] <small>Note18)</small>	0 [Hz]	○
I/O-04	9404	V1 Input Minimum Voltage	V1 Volt x2	0 to 12 [V]	10 [V]	○
I/O-05	9405	V1 Input Maximum Voltage	V1 Freq y2	0 to FU1-30 [Hz] 0 to 100.00 [**] <small>Note18)</small>	60 [Hz]	○
I/O-06	9406	Filtering Time Constant for I Signal Input	I Filter	0 to 9999 [msec]	10 [msec]	○
I/O-07	9407	I Input Minimum Current	I Curr x1	0 to 20 [mA]	4 [mA]	○
I/O-08	9408	Frequency Corresponding to I Input Minimum Current	I Freq y1	0 to FU1-30 [Hz] 0 to 100.00 [**] <small>Note18)</small>	0 [Hz]	○
I/O-09	9409	Filtering Time Constant for I Signal Input	I Curr x2	0 to 20 [mA]	20 [mA]	○
I/O-10	940A	Frequency Corresponding to I Input Maximum Current	I Freq y2	0 to FU1-30 [Hz] 0 to 100.00 [**] <small>Note18)</small>	60 [Hz]	○
I/O-11	940B	Pulse Input Method	P Pulse Set	0 (A+B) 1 (A)	1 (A)	○
I/O-12	940C	Pulse Input Filter	P Filter	0 to 9999 [msec]	10 [msec]	○
I/O-13	940D	Pulse input Minimum Frequency	P Pulse x1	0 to 10 [kHz]	0 [kHz]	○
I/O-14	940E	Frequency Corresponding to I/O-13 Pulse Input Maximum Frequency	P Freq y1	0 to FU1-30 [Hz] 0 to 100.00 [**] <small>Note18)</small>	0 [Hz]	○
I/O-15	940F	Frequency Corresponding to I/O-15	P Pulse x2	0 to 100 [kHz]	10 [kHz]	○
I/O-16	9410	Pulse input Minimum Frequency	P Freq y2	0 to FU1-30 [Hz] 0 to 100.00 [**] <small>Note18)</small>	60 [Hz]	○
I/O-17	9411	Criteria for Analog Input Signal Loss	Wire Broken	0 (None) 1 (Half of x1) 2 (Below x1)	0 (None)	○
I/O-18	9412	Operating Selection at Loss of Freq. Reference	Lost Command	0 (None) 1 (FreeRun) 2 (Stop)	0 (None)	○
I/O-19	9413	Waiting Time after Loss of Freq. Reference	Time Out	0.1 to 120 [sec]	1.0 [sec]	○
I/O-20	9414	Programmable Digital Input Terminal 'M1' Define	M1 Define	0 (Speed-L) 1 (Speed-M) 2 (Speed-H) 3 (XCEL-L) 4 (XCEL-M) 5 (XCEL-H) 6 (Dc-Brake) 7 (2nd Func)	0 (Speed-L)	○

The gray-highlighted codes are hidden parameters and will appear when the related functions are to be set.

Note 17) When DRV-04 is set to either V1, V1S, I or V1+I or Pulse, only selected item codes are displayed in I/O-1-I/O-19.

18) Only user unit displayed when APP-02 or APP-80 is set to [Yes], after APP-06 is set to one of I, V, Pulse, after then when one of I/O-86-I/O-88 is set to either speed, percent, Bar, mBar, kPa, Pa.

Parameter Description

●● I/O GROUP

CODE	Comm. Addr	Description	LCD Keypad Display	Setting Range	Factory Default	Adj. During Run	
I/O-20	9414	Programmable Digital Input Terminal 'M1' Define	M1 Define	8	(Exchange)	0 (Speed-L)	○
				9	(-Reserved-)		
				10	(Up)		
				11	(Down)		
				12	(3-Wire)		
				13	(Ext Trip)		
				14	(Pre-Heat)		
				15	(rTerm Clear)		
				16	(Open-loop)		
				17	(Main-drive)		
				18	(Analog hold)		
				19	(XCEL stop)		
				20	(P Gain2)		
				21	(-Reserved-)		
				22	(Interlock1)		
				23	(Interlock2)		
				24	(Interlock3)		
				25	(Interlock4)		
				26	(Speed_X)		
				27	(RST)		
28	(BX)						
29	(JOG)						
30	(FX)						
31	(RX)						
32	(ANA_CHG)						
33	(Pre-Excite)						
34	(Ext PID Run)						
I/O-21	9415	Programmable Digital Input Terminal 'M2' Define	M2 Define	Same as I/O-20	1 (Speed-M)	○	
I/O-22	9416	Programmable Digital Input Terminal 'M3' Define	M3 Define	Same as I/O-20	2 (Speed-H)	○	
I/O-23	9417	Programmable Digital Input Terminal 'M4' Define	M4 Define	Same as I/O-20	27 (RST)	○	
I/O-24	9418	Programmable Digital Input Terminal 'M5' Define	M5 Define	Same as I/O-20	28 (BX)	○	
I/O-25	9419	Programmable Digital Input Terminal 'M6' Define	M6 Define	Same as I/O-20	29 (JOG)	○	
I/O-26	941A	Programmable Digital Input Terminal 'M7' Define	M7 Define	Same as I/O-20	30 (FX)	○	
I/O-27	941B	Programmable Digital Input Terminal 'M8' Define	M8 Define	Same as I/O-20	31 (RX)	○	

CODE	Comm. Addr	Description	LCD Keypad Display	Setting Range	Factory Default	Adj. During Run	
I/O-28	941C	Terminal Input Status	In Status	0000000000/1111111111	0000000000	*	
I/O-29	941D	Filtering Time Constant for Programmable Digital Input Terminals	Ti Filt Num	2 to 1000 [msec]	15	o	
I/O-30 <small>Note19)</small>	941E	Jog Frequency Setting	Jog Freq	0 to FU1-30	10 [Hz]	o	
I/O-31	941F	Step Frequency 4	Step Freq-4		40 [Hz]	o	
I/O-32	9420	Step Frequency 5	Step Freq-5		50 [Hz]	o	
I/O-33	9421	Step Frequency 6	Step Freq-6		40 [Hz]	o	
I/O-34	9422	Step Frequency 7	Step Freq-7		30 [Hz]	o	
I/O-35	9423	Step Frequency 8	Step Freq-8		20 [Hz]	o	
I/O-36	9424	Step Frequency 9	Step Freq-9		10 [Hz]	o	
I/O-37	9425	Step Frequency 10	Step Freq-10		20 [Hz]	o	
I/O-38	9426	Step Frequency 11	Step Freq-11		30 [Hz]	o	
I/O-39	9427	Step Frequency 12	Step Freq-12		40 [Hz]	o	
I/O-40	9428	Step Frequency 13	Step Freq-13		50 [Hz]	o	
I/O-41	9429	Step Frequency 14	Step Freq-14		40 [Hz]	o	
I/O-42	942A	Step Frequency 15	Step Freq-15		30 [Hz]	o	
I/O-50	9432	Acceleration Time 1 (for Step speed)	Acc Time-1		0 to 6000 [sec]	20 [sec]	o
I/O-51	9433	Deceleration Time 1 (for Step speed)	Dec Time-1		0 to 6000 [sec]	20 [sec]	o
I/O-52 <small>Note20)</small>	9434	Acceleration Time 1 (for Step speed)	Acc Time-2	0 to 6000 [sec]	30 [sec]	o	
I/O-53	9435	Deceleration Time 2	Dec Time-2	0 to 6000 [sec]	30 [sec]	o	
I/O-54	9436	Acceleration Time 3	Acc Time-3	0 to 6000 [sec]	40 [sec]	o	
I/O-55	9437	Deceleration Time 3	Dec Time-3	0 to 6000 [sec]	40 [sec]	o	
I/O-56	9438	Acceleration Time 4	Acc Time-4	0 to 6000 [sec]	50 [sec]	o	
I/O-57	9439	Deceleration Time 4	Dec Time-4	0 to 6000 [sec]	50 [sec]	o	
I/O-58	943A	Acceleration Time 5	Acc Time-5	0 to 6000 [sec]	40 [sec]	o	
I/O-59	943B	Deceleration Time 5	Dec Time-5	0 to 6000 [sec]	40 [sec]	o	
I/O-60	943C	Acceleration Time 6	Acc Time-6	0 to 6000 [sec]	30 [sec]	o	
I/O-61	943D	Deceleration Time 6	Dec Time-6	0 to 6000 [sec]	30 [sec]	o	
I/O-62	943E	Acceleration Time 7	Acc Time-7	0 to 6000 [sec]	20 [sec]	o	
I/O-63	943F	Deceleration Time 7	Dec Time-7	0 to 6000 [sec]	20 [sec]	o	
I/O-70	9446	S0 Output Selection	S0 Mode	0 (Frequency) 1 (Current) 2 (Voltage) 3 (DC link Vtg) 4 (Ext PID Out)	0 (Frequency)	o	
I/O-71	9447	S0 Output Adjustment	S0 Adjust	10 to 200 [%]	100 [%]	o	
I/O-72	9448	S1 Output Selection	S1 Mode	Same as I/O-70	2 (Voltage)	o	
I/O-73	9449	S1 Output Adjustment	S1 Adjust	10 to 200 [%]	100 [%]	o	
I/O-74 <small>Note21)</small>	944A	Frequency Detection Level	FDT Freq	0 to FU1-30 [Hz]	30 [Hz]	o	
I/O-75	944B	Frequency Detection Bandwidth	FDT Band	0 to FU1-30 [Hz]	10 [Hz]	o	
I/O-76	944C	Programmable Digital Output Terminal Define (Aux terminal)	Aux Mode1	0 (None) 1 (FDT-1) 2 (FDT-2) 3 (FDT-3) 4 (FDT-4) 5 (FDT-5) 6 (OL) 7 (IOL)	0 (None)	o	

□ The gray-highlighted codes are hidden parameters and will appear when the related functions are to be set.
 Note 19) I/O-30-I/O-34 displayed only when one of I/O-20-I/O-27 is set to either JOG, Speed_L, Speed_M, Speed_H. I/O-35-I/O-42 displayed only when one of I/O-20-I/O-27 is set to Speed_X.
 20) I/O-52-I/O-63 displayed only when one of I/O-20-I/O-27 is set to either XCEL_L, XCEL_M, XCEL_H.
 21) I/O-74-I/O-75 displayed only when one of I/O-76-I/O-79 is set to either FDT-1-FDT5.



I/O GROUP

CODE	Comm. Addr	Description	LCD Keypad Display	Setting Range	Factory Default	Adj. During Run	
I/O-76	944C	Programmable Digital Output Terminal Define (Aux terminal)	Aux Mode1	8	(Stall)	0 (None)	○
				9	(OV)		
				10	(LV)		
				11	(OH)		
				12	(Lost Command)		
				13	(Run)		
				14	(Stop)		
				15	(Steady)		
				16	(INV line)		
				17	(COMM line)		
				18	(SSearch)		
19	(Ready)						
20	(MMC)						
I/O-77	944D	Programmable Digital Output Terminal Define	Aux Mode2	Same as I/O-76	0 (None)	○	
I/O-78	944E	Programmable Digital Output Terminal Define	Aux Mode3	Same as I/O-76	0 (None)	○	
I/O-79	944F	Programmable Digital Output Terminal Define	Aux Mode4	Same as I/O-76	0 (None)	○	
I/O-80	9450	Fault Output Relay Setting (3A, 3B, 3C)	Relay Mode	000 to 111 [bit]	010 [bit]	○	
I/O-81	9451	Terminal Output Status	Out Status	00000000/11111111	00000000	*	
I/O-82	9452	Waiting time after Fault Output Relay On	Relay On	0 to 9999	0	×	
I/O-83	9453	Waiting time after Fault Output Relay Off	Relay Off	0 to 9999	0	×	
I/O-84	9454	Fan Con Sel (37~90kW)	Fan Mode	0	(Power On Fan)	0	×
				1	(Run Fan)		
				2	(Temper-Fan)		
I/O-85	9455	Fan Temp (37~90kW)	Fan Temper	0 to 70 [°C]	70 [°C]	○	
I/O-86	9456	Voltage Input User Unit Selection	V1 Unit Sel	0	(Speed)	0 (Speed)	×
				1	(Percent)		
				2	(Bar)		
				3	(mBar)		
				4	(kPa)		
5	(Pa)						
I/O-87	9457	Current Input User Unit Selection	I Unit Sel	Same as I/O-86	0 (Speed)	×	
I/O-88	9458	Pulse Input User Unit Selection	Pulse Unit Sel	Same as I/O-86	0 (Speed)	×	
I/O-90	945A	Inverter Number	Inv No.	1 to 250	1	○	
I/O-91 <small>Note22)</small>	945B	Baud Rate Selection	Baud Rate	0	(1200 bps)	3 (9600 bps)	○
				1	(2400 bps)		
				2	(4800 bps)		
				3	(9600 bps)		
				4	(19200 bps)		
I/O-92 <small>Note23)</small>	945C	Operating Method at Loss of Freq. Reference	COM Lost Cmd	0	(None)	0 (None)	○
				1	(FreeRun)		
				2	(Stop)		
I/O-93	945D	Waiting Time after Loss of Freq. Reference	COM Time Out	0.1 to 120 [sec]	1.0 [sec]	○	
I/O-94	945E	Communication Response Delay Time	Delay Time	2 to 1000 [msec]	5 [msec]	○	
I/O-95	945F	A or B Contact	In No/Nc Set	0000000000/1111111111	0000000000	×	
I/O-96	9460	Input Time	In Check Time	1 to 1000	1 [msec]	×	
I/O-97	9461	Overheat Trip Selection	OH Trip Sel	000 to 111 [bit]	010 [bit]	×	
I/O-98	9462	Motor Overheat Trip Temperature	MO Trip Temp	0 to 255 [8C]	110 [8C]	×	

I/O-92 The gray-highlighted codes are hidden parameters and will appear when the related functions are to be set.

Note 22) 38400 bps can be set only when the external communication option card is installed.

23) Only I/O-92 ~ I/O-93 displayed when DRV-03/04 is set to [int485].

APP GROUP

CODE	Comm. Addr	Description	LCD Keypad Display	Setting Range	Factory Default	Adj. During Run
APP-00	9700	Jump to Desired Code #	Jump Code	1 to 99 (LCD Keypad Only)	1	○
APP-01 <small>Note24</small>	9701	Application Mode Selection	App Mode	0 (None) 1 (MMC)	0 (None)	×
APP-02	9702	PID Operation Selection	Proc PI Mode	0 (No) 1 (Yes)	0 (No)	×
APP-03 <small>Note25</small>	9703	PID F Gain Selection	PID F-gain	0 to 999.9[%]	0.0 [%]	○
APP-04 <small>Note26</small>	9704	PID Auxiliary Reference Mode Selection	Aux Ref Mode	0 (No) 1 (Yes)	0 (No)	×
APP-05 <small>Note27</small>	9705	PID Auxiliary Reference Signal Selection	Aux Ref Sel	0 (Keypad-1) 1 (Keypad-2) 2 (V1) 3 (V1S) 4 (I) 5 (V1+I) 6 (Pulse) 7 (Int. 485) 8 (Ext. PID)	2 (V1)	
APP-06	9706	PID Feedback Signal Selection	PID F/B	0 (I) 1 (V1) 2 (Pulse)	0 (I)	
APP-07	9707	P Gain for PID Control	PID P Gain	0 to 999.9 [%]	1.0 [%]	
APP-08	9708	I Gain for PID Control	PID I Time	0 to 32.0 [sec]	10.0 [sec]	
APP-09	9709	D Gain for PID Control	PID D Time	0 to 100 [msec]	0.0 [msec]	
APP-10	970A	High Limit Frequency for PID Control	PID Limit-H	0.00 to FU1-30	60.00 [Hz]	
APP-11	970B	Low Limit Frequency for PID Control	PID Limit-L	FU1-32 to APP-10	0.5 [Hz]	
APP-12	970C	PID Output Scale	PID Out Scale	0.0 to 999.9 [%]	100.0 [%]	
APP-13	970D	PID P2 Gain	PID P2-Gain	0.0 to 999.9 [%]	100.0 [%]	
APP-14	970E	P Gain Scale	P Gain Scale	0.0 to 100.0 [%]	100.0 [%]	
APP-15	960F	PID Output Inverse	Out Inverse	0 (No) 1 (Yes)	0 (No)	
APP-17	9711	PID U Curve Feedback Select	PID U Fbk	0 (No) 1 (Yes)	0 (No)	
APP-20 <small>Note28</small>	9714	2nd Acceleration Time	2nd Acc Time	0 to 6000 [sec]	5 [sec]	
APP-21	9715	2nd Deceleration Time	2nd Dec Time	0 to 6000 [sec]	10 [sec]	
APP-22	9716	2nd Base Frequency	2nd Base Freq	30 to FU1-30 [Hz]	60 [Hz]	
APP-23	9717	2nd V/F Pattern	2nd V/F	0 (Linear) 1 (Square) 2 (User V/F)	0 (Linear)	
APP-24	9718	2nd Forward Torque Boost	2nd F-Boost	0 to 15 [%]	2 [%]	
APP-25	9719	2nd Reverse Torque Boost	2nd R-Boost	0 to 15 [%]	2 [%]	
APP-26	971A	2nd Stall Prevention Level	2nd Stall	30 to 150 [%]	100 [%]	
APP-27	971B	2nd Electronic Thermal Level for 1 minute	2nd ETH 1min	FU2-28 to 200 [%]	130 [%]	
APP-28	971C	2nd Electronic Thermal Level for Continuous	2nd ETH Cont	50 to FU2-27 (Max 150%)	120 [%]	
APP-29	971D	2nd Rated Motor Current	2nd R-Curr	1 to 200 [A]	3.6 [A]	
APP-40 <small>Note29</small>	9728	Number of Auxiliary Motor Run Display	Aux Mot Run	*	*	
APP-41	9729	Aux. Motor Start Selection	Starting Aux	1 to 4	1	
APP-42	972A	Operation Time Display on Auto Change	Auto Op Time	*	*	
APP-43	972B	The Number of Aux Motor	Nbr Aux' s	0 to 7	4	
APP-44	972C	Start Frequency of Aux. Motor 1	Start Freq 1	0 to FU1-30	49.99 [Hz]	

□ The gray-highlighted codes are hidden parameters and will appear when the related functions are to be set.

Note 24 MMC (Multi Motor Control) function is applied to inverters only for 5.5-90kW (7.5-125HP).

25 Only APP-03-APP-17 displayed when APP-02 is set to [Yes] (5.5-90kW/7.5-125HP). Only APP-03-APP-17 and APP-63-APP-65 displayed when APP-2 is set to [Yes] (110-450kW/150-600HP).

26 If APP-04 is set to no, DRV-04 setting will be reference of process PID. And APP-05 setting will be ignored.

27 If APP-04 is set, APP-04 will appear. And APP-05 setting value will be reference of process PID. DRV-04 setting will be ignored.

28 Only APP-20-APP-29 displayed only when one of I/O-20-I/O-27 is set to either "2nd Func".

29 Only APP-40-APP-71 displayed when APP-01 is set to [MMC].

APP GROUP

CODE	Comm. Addr	Description	LCD Keypad Display	Setting Range	Factory Default	Adj. During Run	
APP-45	972D	Start Frequency of Aux. Motor 2	Start Freq 2	0 to FU1-30	49.99 [Hz]		
APP-46	972E	Start Frequency of Aux. Motor 3	Start Freq 3		49.99 [Hz]		
APP-47	972F	Start Frequency of Aux. Motor 4	Start Freq 4		49.99 [Hz]		
APP-48	9730	Start Frequency of Aux. Motor 5	Start Freq 5		49.99 [Hz]		
APP-49	9731	Start Frequency of Aux. Motor 6	Start Freq 6		49.99 [Hz]		
APP-50	9732	Start Frequency of Aux. Motor 7	Start Freq 7		49.99 [Hz]		
APP-51	9733	Stop Frequency of Aux. Motor 1	Stop Freq 1		20.00 [Hz]	○	
APP-52	9734	Stop Frequency of Aux. Motor 2	Stop Freq 2		20.00 [Hz]	○	
APP-53	9735	Stop Frequency of Aux. Motor 3	Stop Freq 3		20.00 [Hz]	○	
APP-54	9736	Stop Frequency of Aux. Motor 4	Stop Freq 4		20.00 [Hz]	○	
APP-55	9737	Stop Frequency of Aux. Motor 5	Stop Freq 5		15.00 [Hz]	○	
APP-56	9738	Stop Frequency of Aux. Motor 6	Stop Freq 6		15.00 [Hz]	○	
APP-57	9739	Stop Frequency of Aux. Motor 7	Stop Freq 7		15.00 [Hz]	○	
APP-58	973A	Delay Time before Operating Aux Motor	Aux Start DT		0.0 to 999.9 [sec]	5.0 [sec]	○
APP-59	973B	Delay Time before Stopping Aux Motor	Aux Stop DT	0.0 to 999.9 [sec]	5.0 [sec]	○	
APP-60	973C	Accel Time when Number of Pump Decreases	PID Acc Time	0 to 600.0 [sec]	2.0 [sec]	○	
APP-61	973D	Decel Time when Number of Pump Increases	PID Dec Time	0 to 600.0 [sec]	2.0 [sec]	○	
APP-62	973E	PID Bypass Selection	Regul Bypass	0	(No)	0 (No)	×
				1	(Yes)		
APP-63	973F	Sleep Delay Time	Sleep Delay	0.0 to 9999 [sec]	60.0 [sec]	○	
APP-64	9740	Sleep Frequency	Sleep Freq	0 to FU1-30 [Hz]	0.00 [Hz]	○	
APP-65	9741	Wake-Up Level	Wake Up Level	0.0 to 100.0 [%]	35.0 [%]	○	
APP-66	9742	Auto Change Mode Selection	Auto Ch_Mode	0, 1 (Aux), 2 (Main)	0	○	
APP-67	9743	Auto Change Time	Auto Ex-Intv	00:00 to 99:00	72:00	○	
APP-68	9744	Auto Change Level	Auto Ex-Level	FU1-32 to FU1-30 [Hz]	20.0 [Hz]	○	
APP-69	9745	Inter-Lock Selection	Inter-Lock	0	(No)	0 (No)	○
				1	(Yes)		
APP-71	9747	Pressure Difference for Aux Motor Stop	Actual Pr Diff	0 to 100 [%]	2 [%]	○	
APP-74	974A	PrePID Reference Frequency	PrePID Freq	0 to FU1-30	0	○	
APP-75	974B	PrePID Exit Level	PrePID Exit	0 to 100.0 [%]	0	○	
APP-76	974C	PrePID Stop Delay	PrePID Dly	0 to 9999	600	○	
APP-80	9750	Ext PID Operation Selection	Ext PI Mode	0	(No)	0 (No)	×
				1	(Yes)		
APP-81 <small>Note30</small>	9751	Ext PID Reference Signal Selection	Ext Ref Sel	0	(I)	3 (Key-Pad)	×
				1	(V1)		
				2	(Pulse)		
				3	(Key-Pad)		
APP-82	9752	Ext PID Reference Level	Ext Ref Perc	0 to 100.00 [%]	50.00 [%]	×	
APP-83	9753	Ext PID Feedback Signal Selection	Ext Fbk Sel	0	(I)	0 (I)	×
				1	(V1)		
				2	(Pulse)		
APP-85	9755	P Gain for ExtPID	ExtPID P Gain	0 to 999.9 [%]	1.0 [%]	×	
APP-86	9756	I Time for ExtPID	ExtPID I Time	0 to 32.0 [sec]	10.0 [sec]	×	
APP-87	9757	D Time for ExtPID	ExtPID D Time	0 to 2000 [msec]	0 [msec]	×	
APP-88	9758	High Limit Frequency for ExtPID Control	ExtPID lmt-H	0 to 100.00 [%]	100.00 [%]	×	
APP-89	9759	Low Limit Frequency for ExtPID Control	ExtPID lmt-L	0 to 30.00 [%]	0 [%]	×	
APP-90	975A	ExtPID Output Scale	ExtPID Scale	0 to 999.9 [%]	100.0 [%]	×	
APP-91	975B	ExtPID P2 Gain	Ext P2 Gain	0 to 999.9 [%]	100.0 [%]	×	
APP-92	975C	ExtPID P Gain Scale	Ext P Scale	0 to 100.0 [%]	100.0 [%]	×	
APP-93	975D	ExtPID F Gain	ExtPID F Gain	0 to 999.9 [%]	0.0 [%]	○	
APP-95	975F	ExtPID Output Inverse	ExtOut Inverse	0	(No)	0 (No)	×
				1	(Yes)		
APP-97	9761	ExtPID Loop Time	Ext Loop Time	50 to 200 [msec]	100 [msec]	×	

□ The gray-highlighted codes are hidden parameters and will appear when the related functions are to be set.

Note 30) Only APP-81~APP-97 displayed when APP-80 is set to [Yes].

Trial Run

❖ Operation Example (1)

V/F Control + Analog Voltage Input (V1)
+ Operation via Terminal (FX/RX)

Operation condition

- Control mode: V/F control
- Frequency command: 50 [Hz] analog input via V1 terminal
- Accel/Decel time: Accel – 15 [sec], Decel – 25 [sec]
- Drive mode: Run/Stop via FX/RX terminal, Control terminal: NPN mode

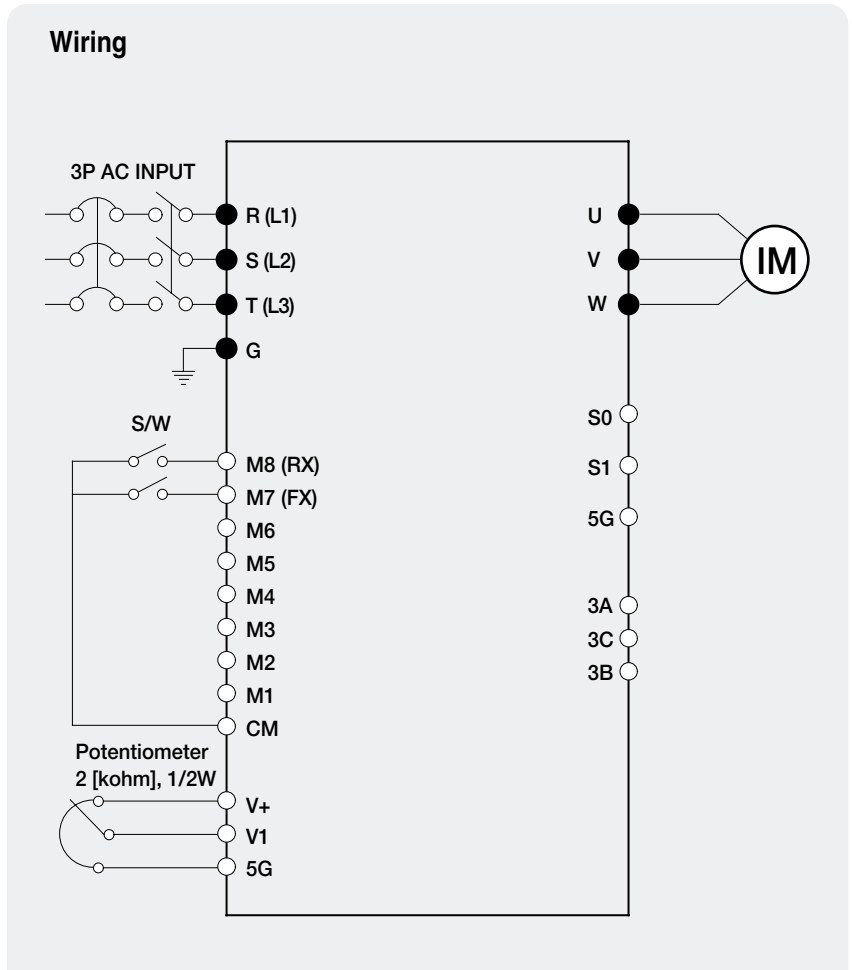

Step	Parameter setting	Code	Description
1	Control Mode Selection	FU2-60	Set it to 0 (V/F).
2	Drive Mode	DRV-3	Set it to Fx/Rx-1.
3	Frequency Mode	DRV-4	Set V1 Analog input value in frequency mode.
4	50 [Hz] Freq Command Setting	DRV-0	Set freq command 50 [Hz] via V1 (Potentiometer).
5	Accel/Decel Time	DRV-1 DRV-2	Set Accel time to 15 [sec] in DRV-2. Set Decel time to 25 [sec] in DRV-3.
6	Terminal FX	I/O-26	Motor starts to rotate in forward direction at 50Hz with Accel time 15 [sec] when FX terminal is turned ON. Motor decelerates to stop with Decel time 25 [sec] when FX terminal is turned OFF.
7	Terminal RX	I/O-27	When RX terminal is turned ON motor starts to rotate in Reverse direction at 50 [Hz] with Accel time 15 [sec]. When it is OFF, motor decelerates to stop with Decel time 25 [sec].

Operation Example (2)

V/F control + Analog input (V1S)
+ Operation via terminal FX/RX

Operation condition

- Control mode: V/F control
- Frequency command: Setting 50 [Hz] via Analog input (V1S)
- Accel/Decel time: Accel time 15 [sec], Decel time 25 [sec]
- Drive mode: Run/Stop via FX/RX, Control terminal: NPN mode

Wiring

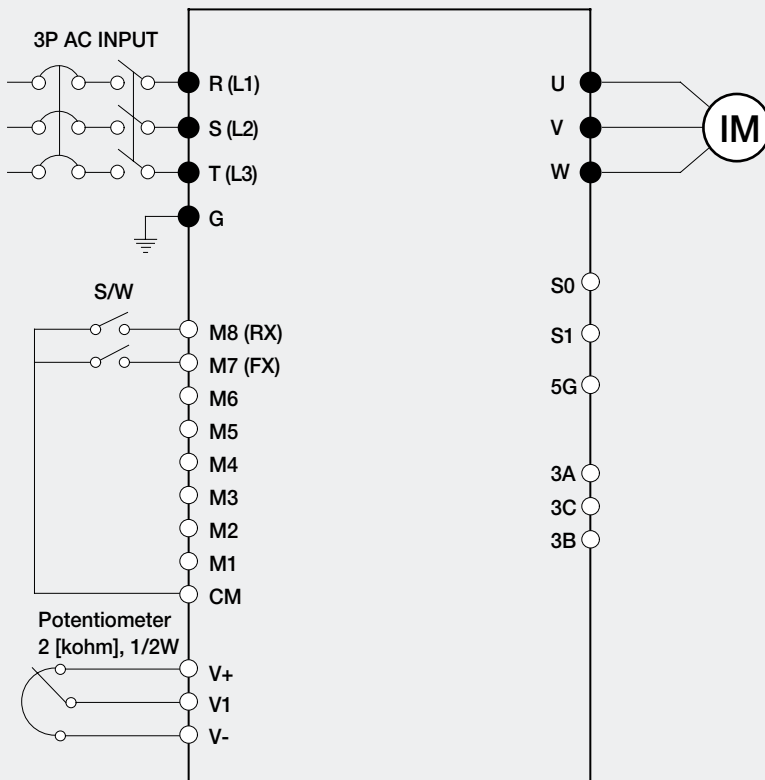

Step	Parameter setting	Code	Description
1	Control Mode Selection	FU2-60	Set it to 0 (V/F).
2	Drive Mode	DRV-3	Set it to 1 (Fx/Rx-1).
3	Frequency Mode	DRV-4	Set it to 3 (V1S).
4	Operating Frequency Command 50 [Hz] Setting	DRV-0	Set 50 [Hz] via potentiometer (V1S).
5	Accel/Decel Time Setting	DRV-1 DRV-2	Set accel time to 15 [sec] in DRV-1 with decal time to 25 [sec] in DRV-2.
6	FX Terminal (M7)	IO-26	When FX terminal is turned ON, motor rotating in forward direction starts running at 50 [Hz] for 15 [sec]. When FX terminal is turned OFF, motor decelerates to stop for 25 [sec].
7	RX Terminal (M8)	IO-27	When RX terminal is turned ON, motor rotating in reverse direction starts running at 50 [Hz] for 15 [sec]. When RX terminal is turned OFF, motor decelerates to stop for 25 [sec].

Dimensions

SV055iP5A (200/400V Class)

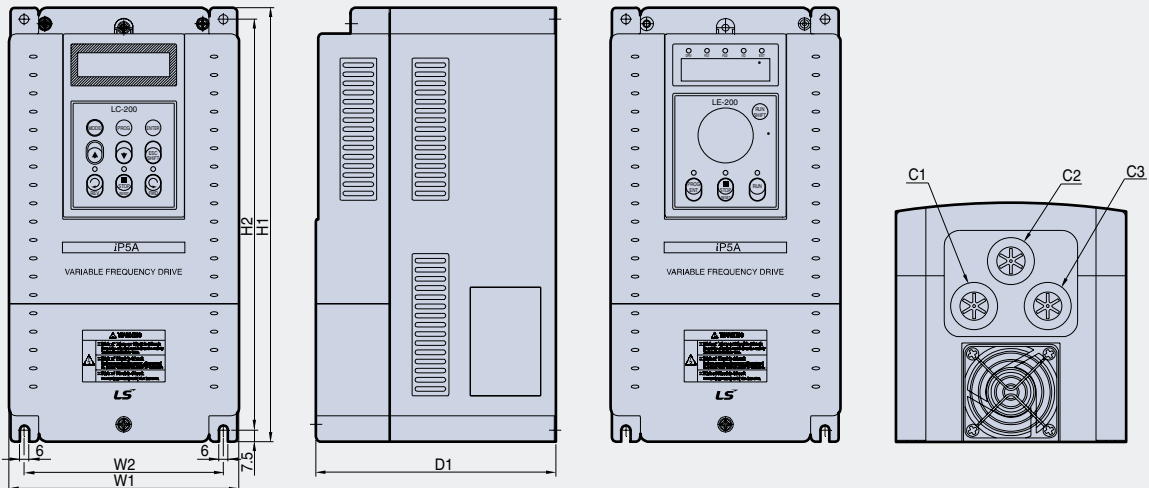

mm (inches)

Model	W1	W2	H1	H2	D1	C1	C2	C3	Enclosure Type
SV055iP5A-2/4	150 (5.91)	130 (5.12)	284 (11.18)	269 (10.69)	156.5 (6.16)	24 (0.98)	24 (0.98)	24 (0.98)	IP20 UL Type 1

SV075~300iP5A (200/400V Class)

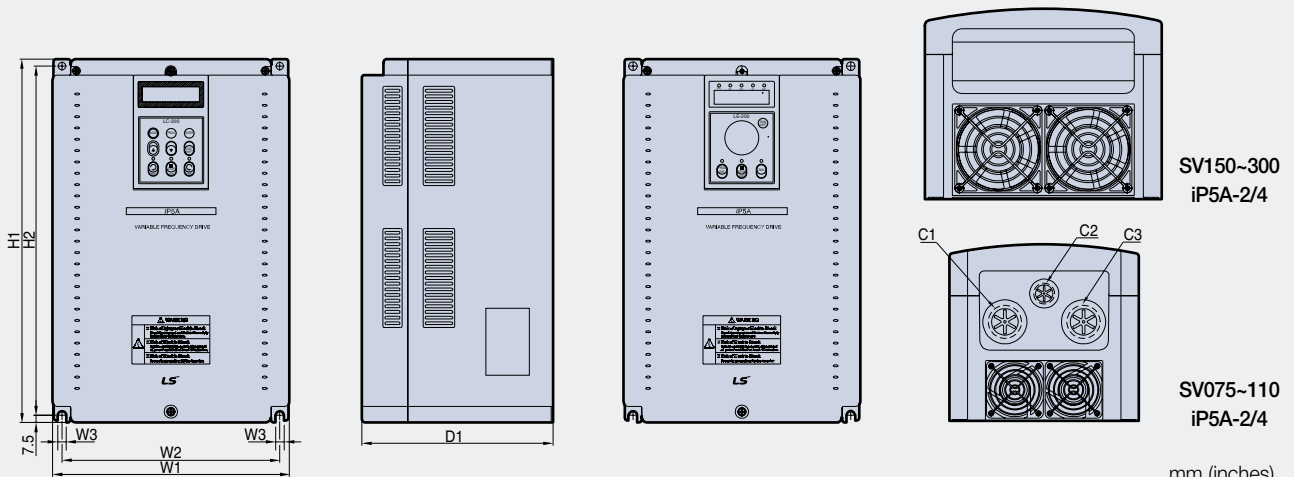

mm (inches)

Model	W1	W2	W3	H1	H2	D1	C1	C2	C3	Enclosure Type
SV075iP5A-2/4	200 (7.87)	180 (7.09)	6 (0.23)	284 (11.18)	269 (10.69)	182 (7.16)	35 (1.37)	24 (0.98)	35 (1.37)	IP20 UL Type 1
SV110iP5A-2/4	200 (7.87)	180 (7.09)	6 (0.23)	284 (11.18)	269 (10.69)	182 (7.16)	35 (1.37)	24 (0.98)	35 (1.37)	IP20 UL Type 1
SV150iP5A-2/4	250 (9.84)	230 (9.06)	9 (0.35)	385 (15.16)	370 (14.57)	201 (7.91)	-	-	-	IP00 UL Open
SV185iP5A-2/4	250 (9.84)	230 (9.06)	9 (0.35)	385 (15.16)	370 (14.57)	201 (7.91)	-	-	-	IP00 UL Open
SV220iP5A-2/4	304 (11.97)	284 (11.18)	9 (0.35)	460 (18.11)	445 (17.52)	234 (9.21)	-	-	-	IP00 UL Open
SV300iP5A-2/4	304 (11.97)	284 (11.18)	9 (0.35)	460 (18.11)	445 (17.52)	234 (9.21)	-	-	-	IP00 UL Open

Dimensions

SV150~300iP5A (UL Type 1 or UL Open Type with Conduit Option used, 200V/400V Class)

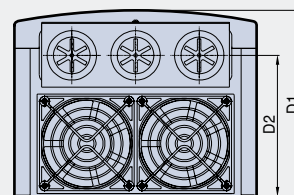
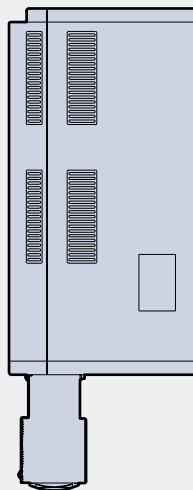
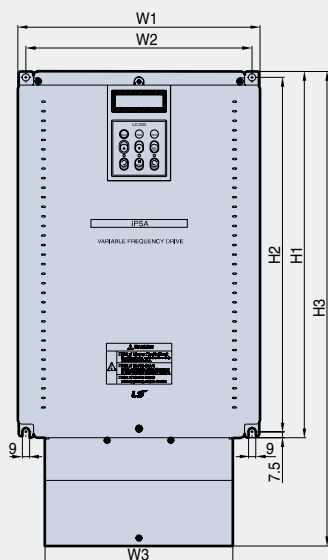

Note) Mounting NEMA 1 conduit option to the 15~90kW (20~125HP) Open Type meets NEMA 1 but does not comply with UL Enclosed Type 1. To that end, please purchase UL Type 1 product.

mm (inches)

Model	W1	W2	H1	H2	H3	D1	D2	C3	Enclosure Type
SV150iP5A-2/4	250 (9.84)	230 (9.06)	200.8 (7.9)	385 (15.16)	370 (14.57)	454.2 (17.88)	201 (7.91)	146 (5.74)	IP20 UL Type 1
SV185iP5A-2/4	250 (9.84)	230 (9.06)	200.8 (7.9)	385 (15.16)	370 (14.57)	454.2 (17.88)	201 (7.91)	146 (5.74)	IP20 UL Type 1
SV220iP5A-2/4	304 (11.97)	284 (11.18)	236 (9.29)	460 (18.11)	445 (17.52)	599.2 (23.59)	234 (9.21)	177.5 (6.98)	IP20 UL Type 1
SV300iP5A-2/4	304 (11.97)	284 (11.18)	236 (9.29)	460 (18.11)	445 (17.52)	599.2 (23.59)	234 (9.21)	177.5 (6.98)	IP20 UL Type 1

SV150~SV300 iP5A (400V Class)–Built-in DCL Type

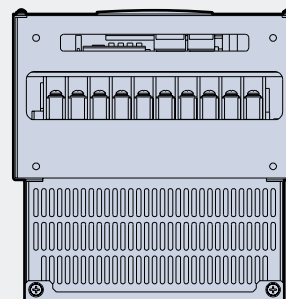
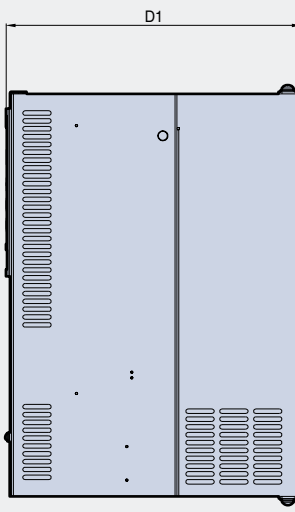
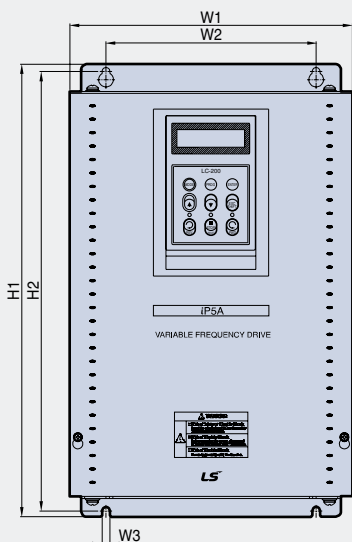

mm (inches)

Model	W1	W2	W3	H1	H2	D1	Enclosure Type
SV150, 185iP5A-4L	250 (9.84)	186 (7.32)	7 (0.28)	403.5 (15.88)	392 (15.43)	261.2 (10.28)	IP00 UL Type 1
SV220, 300iP5A-4L	260 (10.23)	220 (8.66)	7 (0.28)	480 (18.89)	468.5 (18.44)	268.6 (10.57)	IP20 UL Type 1

●● SV150~SV300 iP5A (Built-in DCL Type, UL Type 1 or UL Open Type with Conduit Option used, 400V Class)

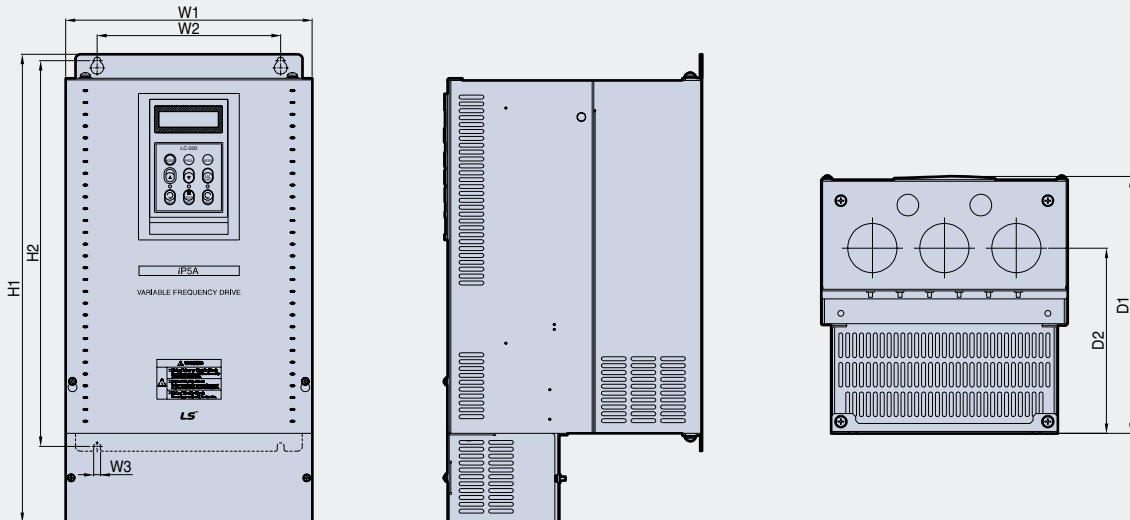

mm (inches)

Model	W1	W2	W3	H1	H2	D1	D2	Enclosure Type
SV150, 185iP5A-4L	250 (9.84)	186 (7.32)	7 (0.28)	475.5 (18.72)	392 (15.43)	261.2 (10.28)	188.4 (7.42)	IP20 UL Type 1
SV220, 300iP5A-4L	260 (10.23)	220 (8.66)	7 (0.28)	552 (21.73)	468.5 (18.44)	268.6 (10.57)	188.8 (7.43)	IP20 UL Type 1

●● SV370~SV550iP5A (400V Class)

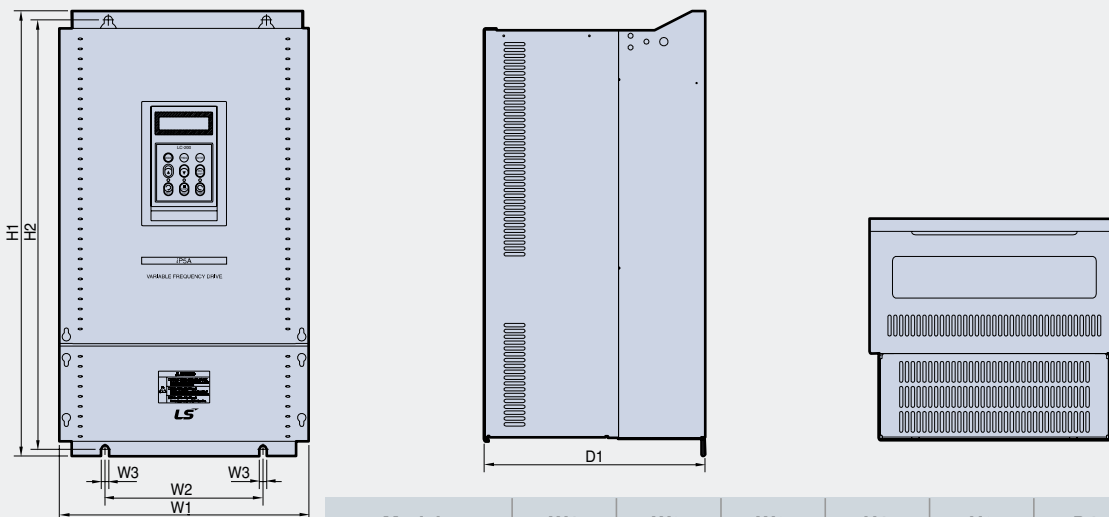

mm (inches)

Model	W1	W2	W3	H1	H2	D1	Enclosure Type
SV370, 450iP5A-4	300 (11.81)	190 (7.48)	9 (0.35)	534 (21.02)	515 (20.28)	265.6 (10.46)	IP00 UL Open
SV550iP5A-4	300 (11.81)	190 (7.48)	9 (0.35)	534 (21.02)	515 (20.28)	292.6 (11.52)	IP00 UL Open
SV370, 450iP5A-4L (Built-in DCL Type)	300 (11.81)	190 (7.48)	9 (0.35)	684 (26.92)	665 (26.18)	265.6 (10.46)	IP00 UL Open
SV550iP5A-4L (Built-in DCL Type)	300 (11.81)	190 (7.48)	9 (0.35)	684 (26.92)	665 (26.18)	292.6 (11.52)	IP00 UL Open

Dimensions

SV370~550iP5A (UL Type 1 or UL Open Type with Conduit Option Used, 400V Class)

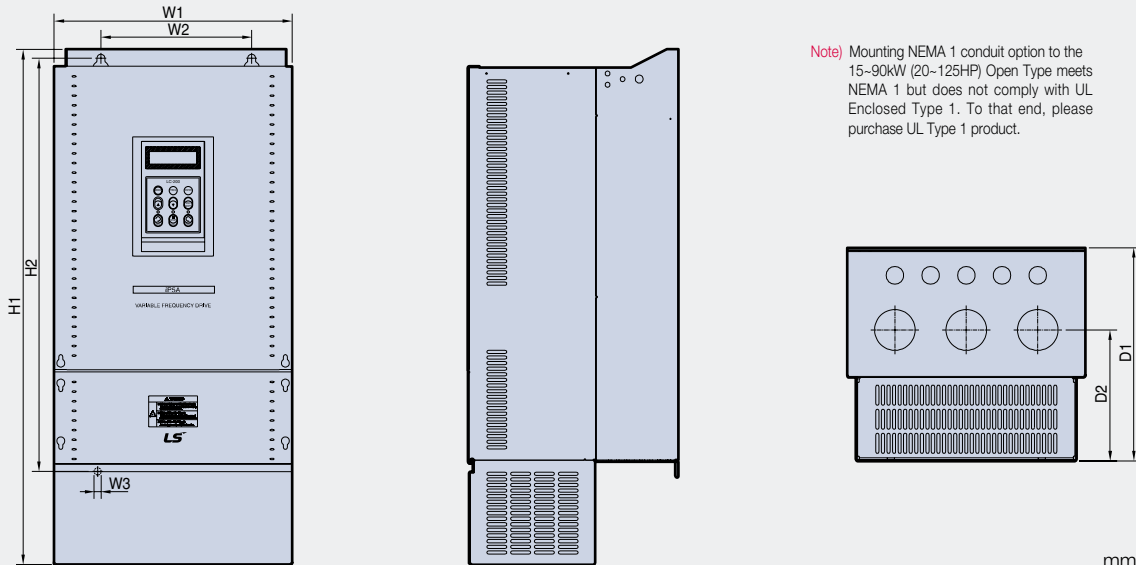

Note) Mounting NEMA 1 conduit option to the 15~90kW (20~125HP) Open Type meets NEMA 1 but does not comply with UL Enclosed Type 1. To that end, please purchase UL Type 1 product.

mm (inches)

Model	W1	W2	W3	H1	H2	D1	D2	Enclosure Type
SV370, 450iP5A-4	300 (11.81)	190 (7.48)	9 (0.35)	642 (25.28)	515 (20.28)	265.6 (10.46)	163.4 (6.43)	IP20 UL Type 1
SV550iP5A-4	300 (11.81)	190 (7.48)	9 (0.35)	642 (25.28)	515 (20.28)	292.6 (11.52)	190.4 (7.5)	IP20 UL Type 1
SV370, 450iP5A-4L	300 (11.81)	190 (7.48)	9 (0.35)	792 (31.18)	665 (26.18)	265.6 (10.46)	163.4 (6.43)	IP20 UL Type 1
SV550iP5A-4L	300 (11.81)	190 (7.48)	9 (0.35)	792 (31.18)	665 (26.18)	292.6 (11.52)	190.4 (7.5)	IP20 UL Type 1

SV750, 900iP5A (400V Class)

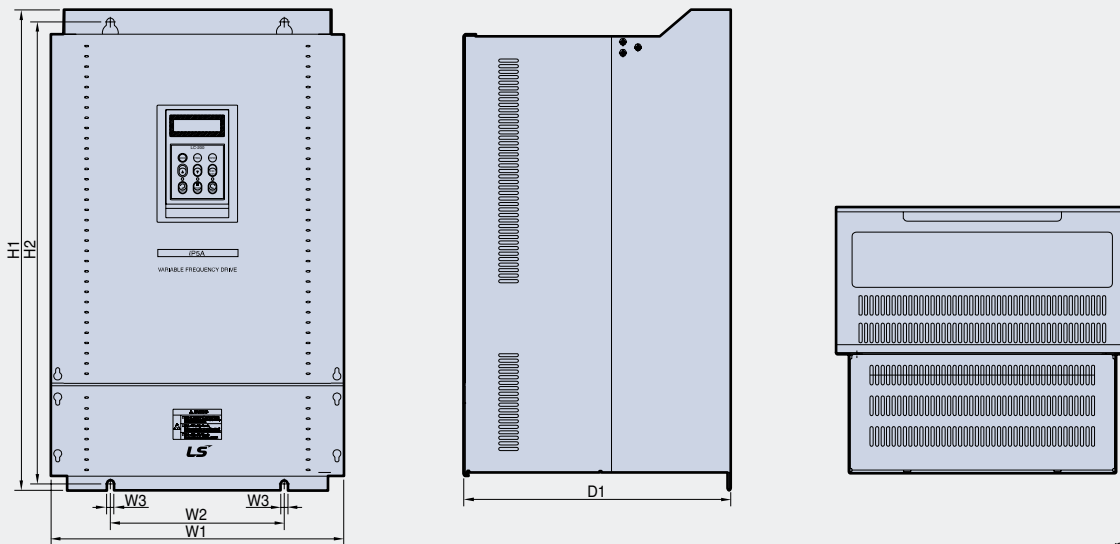

mm (inches)

Model	W1	W2	W3	H1	H2	D1	Enclosure Type
SV750, 900iP5A-4	370 (14.57)	220 (8.66)	9 (0.35)	610 (24.02)	586.5 (23.09)	337.6 (13.29)	IP00 UL Open
SV750, 900iP5A-4L (Built-in DCL Type)	370 (14.57)	220 (8.66)	9 (0.35)	760 (29.92)	736.6 (28.99)	337.6 (13.29)	IP00 UL Open

●● SV750, 900iP5A (UL Type 1 or UL Open Type with Conduit Option used, 400V Class)

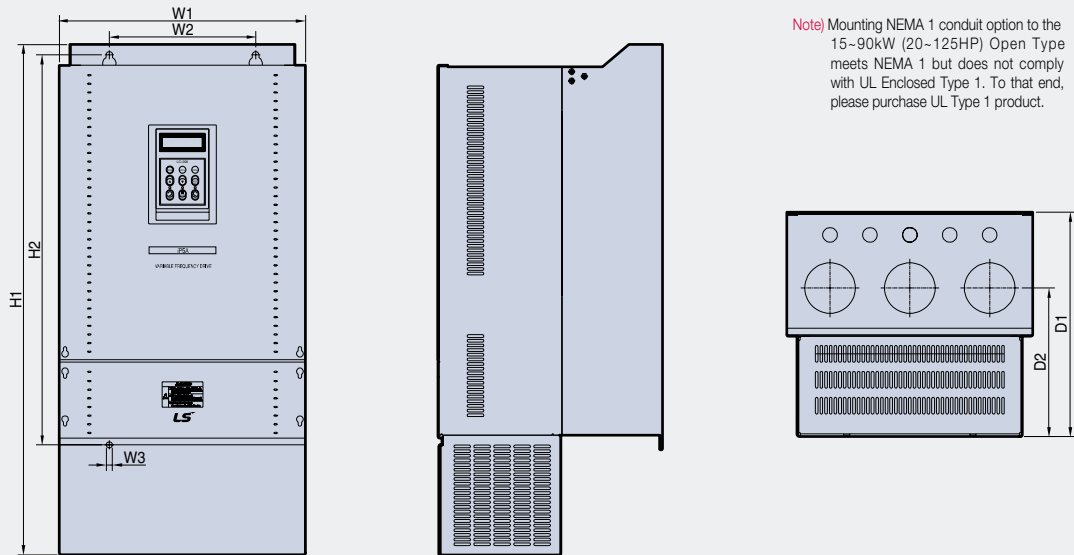

mm (inches)

Model	W1	W2	W3	H1	H2	D1	D2	Enclosure Type
SV750, 900iP5A-4	370 (14.57)	220 (8.66)	9 (0.35)	767.5 (30.22)	586.5 (23.09)	337.6 (13.29)	223.4 (8.8)	IP20 UL Type 1
SV750, 900iP5A-4L (Built-in DCL Type)	370 (14.57)	220 (8.66)	9 (0.35)	917.5 (36.12)	736.5 (28.99)	337.6 (13.29)	223.4 (8.8)	IP20 UL Type 1

●● SV1100, 1600iP5A (400V Class)

mm (inches)

Model	W1	W2	W3	H1	H2	D1	Enclosure Type
SV1100, 1320iP5A-4L	510 (20.08)	381 (15.00)	11 (0.43)	768.5 (30.26)	744 (29.29)	422.6 (16.64)	IP00 UL Open
SV1600iP5A-4L	510 (20.08)	381 (15.00)	11 (0.43)	844 (33.23)	819.5 (32.26)	422.6 (16.64)	IP00 UL Open

●● SV2200, 2800iP5A (400V Class)

mm (inches)

Model	W1	W2	W3	H1	H2	D1	Enclosure Type
SV2200, 2800iP5A-4L	690 (27.17)	581 (22.87)	14 (0.55)	1063 (41.85)	1028 (40.49)	449.6 (17.70)	IP00 UL Open

●● SV3150, 4500iP5A (400V Class)

mm (inches)

Model	W1	W2	W3	H1	H2	D1	Enclosure Type
SV3150, iP5A-4L	772 (30.39)	500 (19.69)	13 (0.51)	1140.5 (44.90)	1110 (43.70)	442 (17.40)	IP00 UL Open
SV3750, 4500iP5A-4L	922 (36.30)	580 (22.83)	14 (0.55)	1302.5 (51.28)	1271.5 (50.06)	495 (19.49)	IP00 UL Open

DB (Dynamic Braking) Unit

DBU Models

UL	Inverter	Applicable motor rating	DB Unit	Dimension
Non UL type	200V class	11~15 kW (15~20 HP)	SV150DBU-2	Group 1.
		18.5~22 kW (25~30 HP)	SV220DBU-2	
		30~37 kW (40~50 HP)	SV037DBH-2	Group 2.
		45~55 kW (60~75 HP)	SV037DBH-2, 2set	
	400V class	11~15 kW (15~20 HP)	SV150DBU-4	Group 1.
		18.5~22 kW (25~30 HP)	SV220DBU-4	Group 2.
		30~37 kW (40~50 HP)	SV037DBH-4	
		45~55 kW (60~75 HP)	SV075DBH-4	
		75 kW (100 HP)		
	UL type	200V class	11~15 kW (15~20 HP)	SV150DBU-2U
18.5~22 kW (25~30 HP)			SV220DBU-2U	
30~37 kW (40~50 HP)			SV370DBU-2U	
45~55 kW (60~75 HP)			SV550DBU-2U	
400V class		11~15 kW (15~20 HP)	SV150DBU-4U	
		18.5~22 kW (25~30 HP)	SV220DBU-4U	
		30~37 kW (40~50 HP)	SV370DBU-4U	
		45~55 kW (60~75 HP)	SV550DBU-4U	
		75 kW (100 HP)	SV750DBU-4U	
		90~110 kW (125~150 HP)	SV550DBU-4, 2set	
		132~160 kW (200~250 HP)	SV750DBU-4, 2set	
		220 kW (300 HP)	SV750DBU-4, 3set	
		280~315 kW (350~400 HP)	-	
		375~450 kW (500~600 HP)	-	

Terminal Configuration

- Group 1 - **CM** **OH** **G** **B2** **B1** **N** **P**
- Group 2 - **G** **N** **B2** **P/B1**
- Group 3 - **P** **N** **G** **B1** **B2**

Terminals	Description	Terminals	Description
G	Ground terminal	N	Connect to inverter terminal N
B2	Connect to DB Resistor's B2	P	Connect to inverter terminal P1
B1	Connect to DB Resistor's B1	CM	OH common
N	Connect to inverter terminal N	OH*	Over Heat Trip output terminal (Open Collector output: 20mA, 27V DC)
P	Connect to inverter terminal P1		

⚡ Wiring for DB unit and DB resistor (For 5.5~90kW/7.5~125HP inverters)

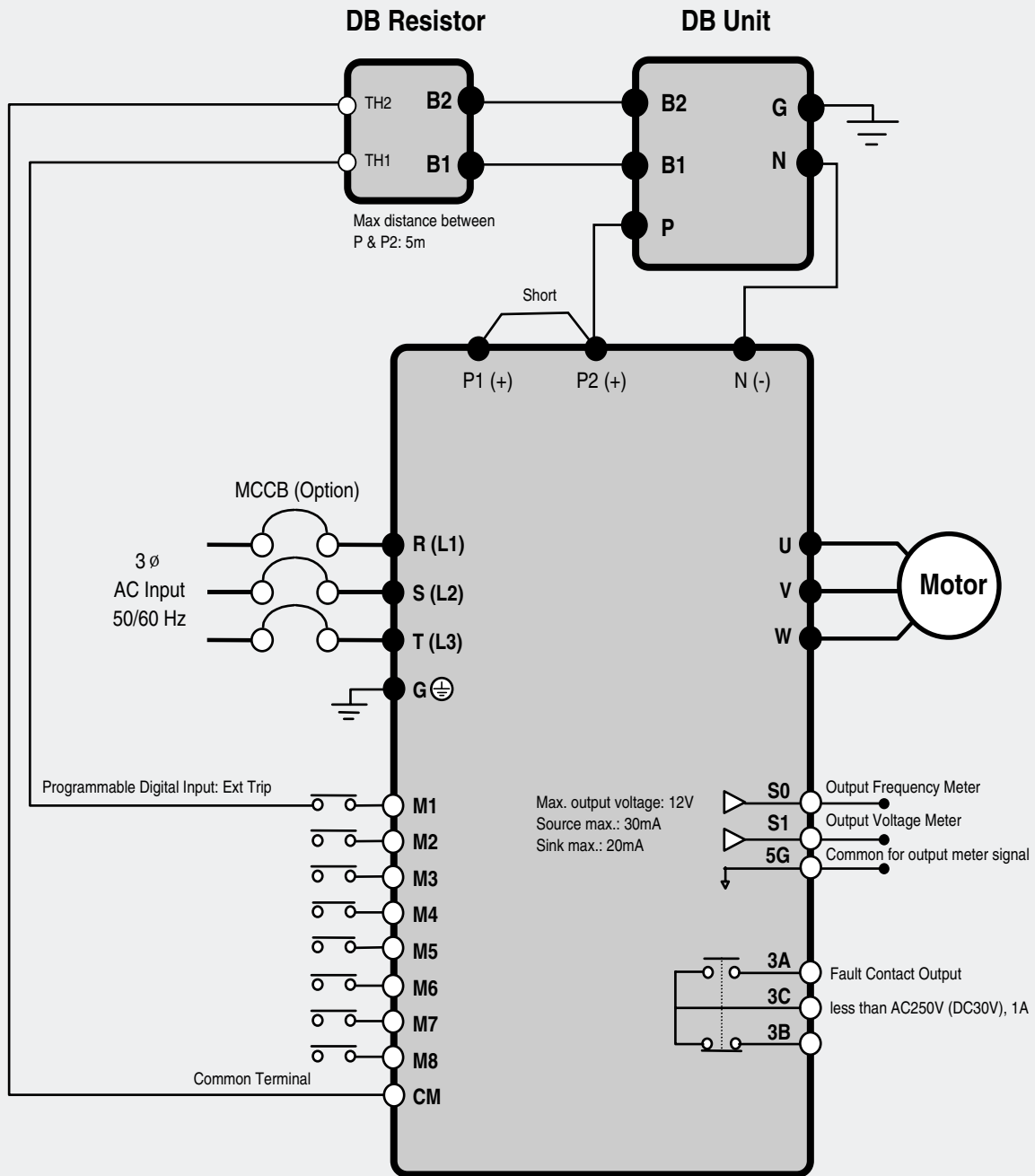

DB resistor terminal	Description
B1, B2	Wire terminal properly based on wiring block diagram. Connect a DB resistor to the DB Unit's B1, B2 terminals.
TH1, TH2	Thermal sensor terminal of DB resistor. Normal temperature (Ambient): Contact ON (TH1-TH2 closed) DB resistor overheated: Contact OFF (TH1-TH2 Open). Wire it to the inverter terminal defined as External Trip.

DB (Dynamic Braking) Unit

Group 1

(Unit: mm)

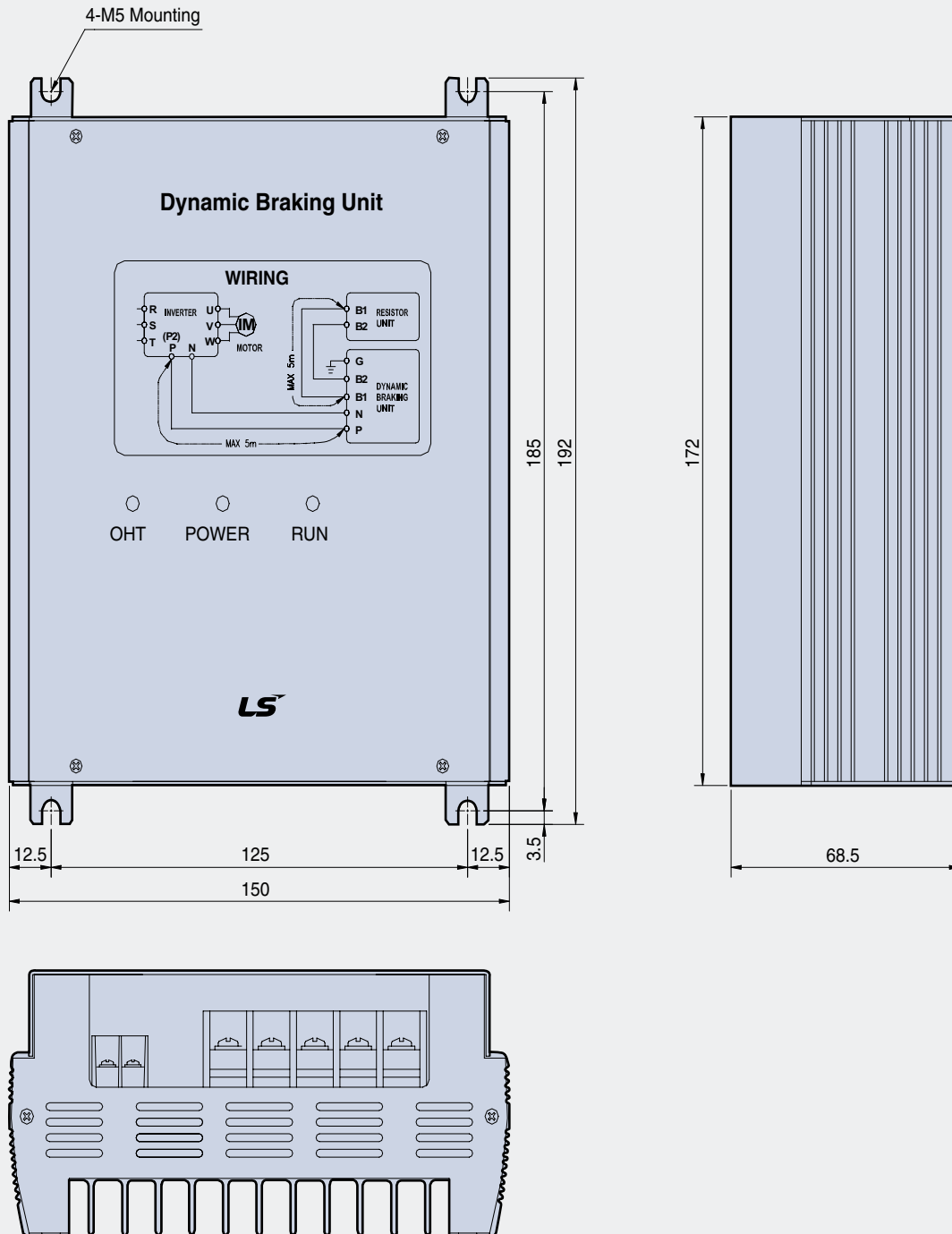

Group 2

(Unit: mm)

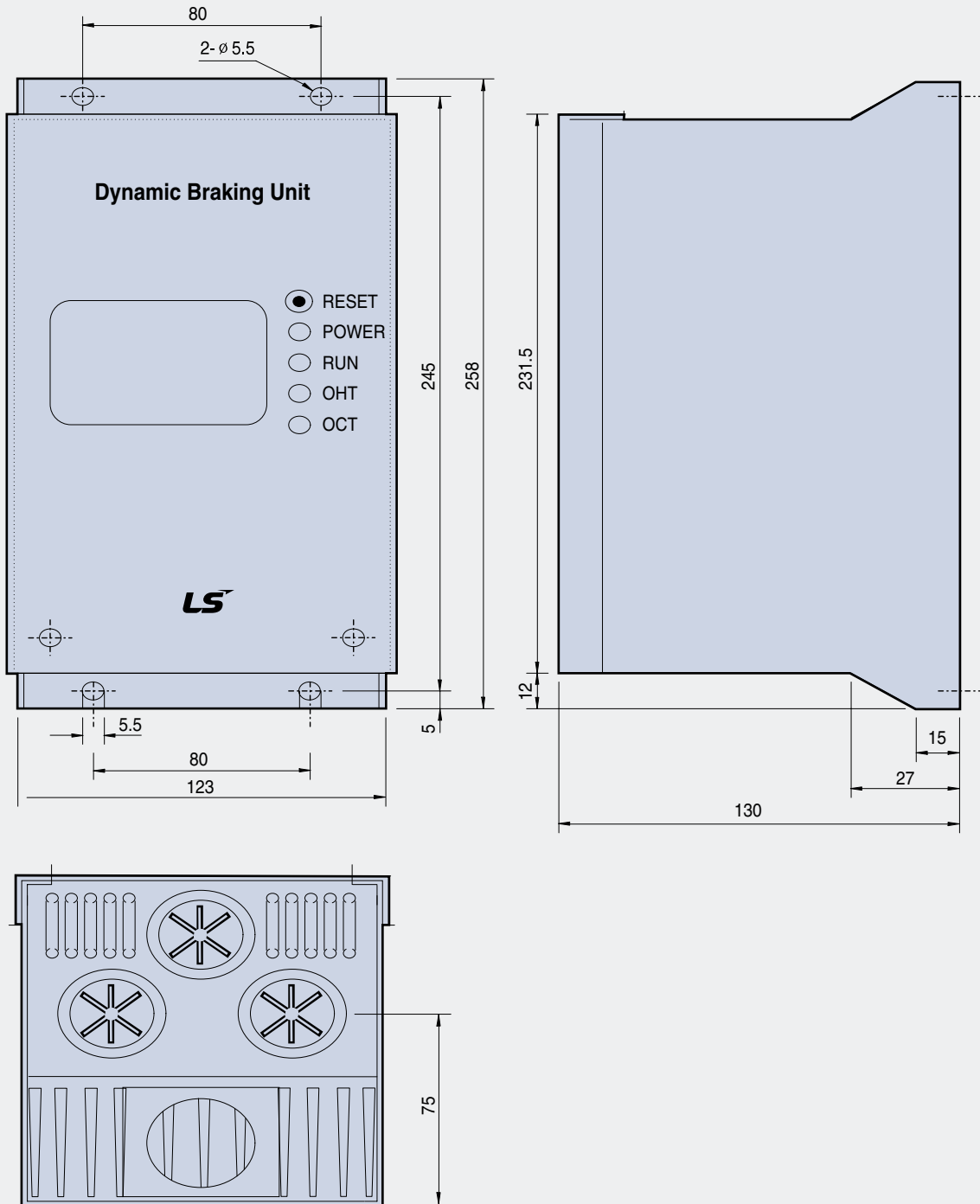

DB (Dynamic Braking) Unit

Group 3

(Unit: mm)

4-M5 Mounting

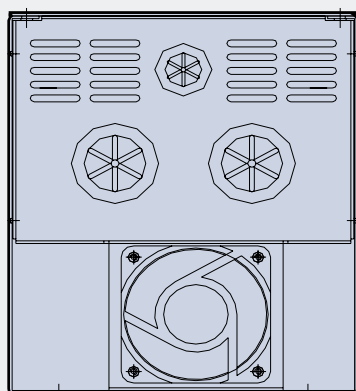
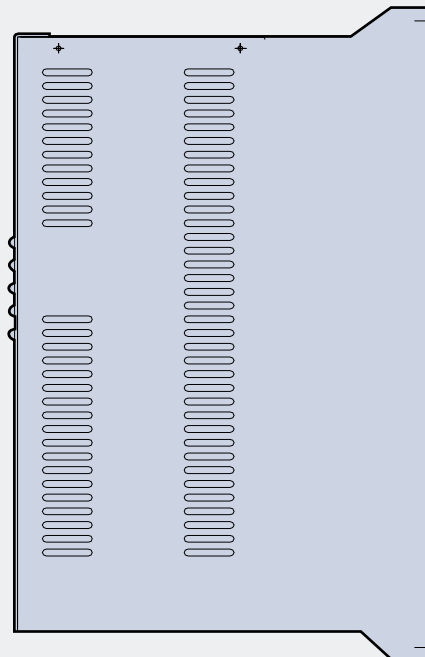
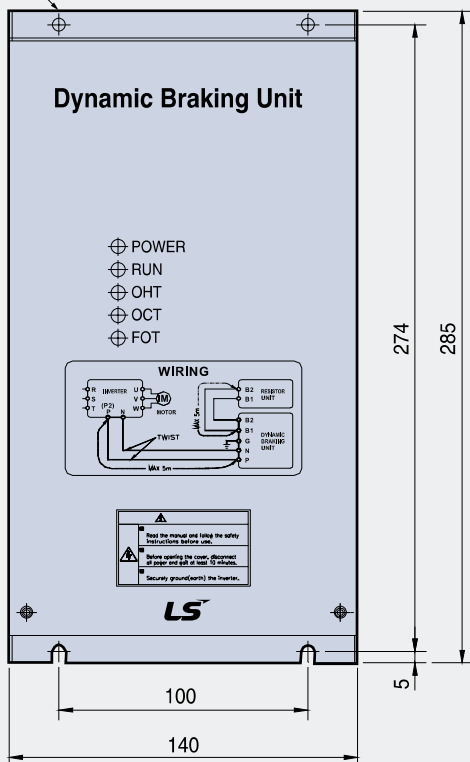

External DB Resistor

iP5A do not have built-in DB resistor on power stack as factory installation. External DB Unit and Resistor (Optional) should be installed. See the following table for more details (ED: 5%, Continuous Braking Time: 15 sec). If Enable duty (%ED) is increased to 10%, use external DB resistor having twice Wattage rating.

Applied motor capacity (kW/HP)	Operating rate (ED/Continuous Braking Time)	100 % Braking Torque			150% Braking Torque			
		[ohm]	[W]	Type	[ohm]	[W]	Type	
200V	5.5/7.5	5%/15 sec	30	700	Type3	20	800	Type 3
	7.5/10	5%/15 sec	20	1000	Type 3	15	1200	Type 3
	11/15	5%/15 sec	15	1400	Type 3	10	2400	Type 3
	15/20	5%/15 sec	11	2000	Type 3	8	2400	Type 3
	18.5/25	5%/15 sec	9	2400	Type 3	5	3600	Type 3
	22/30	5%/15 sec	8	2800	Type 3	5	3600	Type 3
	30/40	10%/6 sec	4.2	6400	-	-	-	-
400V	5.5/7.5	5%/15 sec	120	700	Type 3	85	1000	Type 3
	7.5/10	5%/15 sec	90	1000	Type 3	60	1200	Type 3
	11/15	5%/15 sec	60	1400	Type 3	40	2000	Type 3
	15/20	5%/15 sec	45	2000	Type 3	30	2400	Type 3
	18.5/25	5%/15 sec	35	2400	Type 3	20	3600	Type 3
	22/30	5%/15 sec	30	2800	Type 3	20	3600	Type 3
	30/40	10%/6 sec	16.9	6400	-	-	-	-
	37/50	10%/6 sec	16.9	6400	-	-	-	-
	45/60	10%/6 sec	11.4	9600	-	-	-	-
	55/75	10%/6 sec	11.4	9600	-	-	-	-
	75/100	10%/6 sec	8.4	12800	-	-	-	-
	90/125	10%/6 sec	8.4	12800	-	-	-	-

Peripheral Device

⚡ MCCB (Molded Case Circuit Breaker) and MC (Magnetic Contactor)

Voltage	Motor [kW]	Inverter Model	MCCB (LS Industrial Systems)	MC (LS Industrial Systems)
200V Class	5.5	SV055iP5A-2	ABS53b/50A	GMC-40
	7.5	SV075iP5A-2	ABS63b/60A	GMC-40
	11	SV110iP5A-2	ABS103b/100A	GMC-50
	15	SV150iP5A-2	ABS103b/100A	GMC-85
	18.5	SV185iP5A-2	ABS203b/125A	GMC-100
	22	SV220iP5A-2	ABS203b/150A	GMC-100
	30	SV300iP5A-2	ABS203b/175A	GMC-150

⚡ MCCB (Molded Case Circuit Breaker) and MC (Magnetic Contactor)

Voltage	Motor [kW]	Inverter Model	MCCB (LS Industrial Systems)	MC (LS Industrial Systems)
400V Class	5.5	SV055iP5A-4	ABS33b/30A	GMC-22
	7.5	SV075iP5A-4	ABS33b/30A	GMC-22
	11	SV110iP5A-4	ABS53b/50A	GMC-40
	15	SV150iP5A-4	ABS63b/60A	GMC-50
	18.5	SV185iP5A-4	ABS63b/60A	GMC-50
	22	SV220iP5A-4	ABS103b/100A	GMC-65
	30	SV300iP5A-4	ABS103b/100A	GMC-75
	37	SV370iP5A-4	ABS203b/125A	GMC-100
	45	SV450iP5A-4	ABS203b/150A	GMC-125
	55	SV550iP5A-4	ABS203b/175A	GMC-150
	75	SV750iP5A-4	ABS203b/225A	GMC-180
	90	SV900iP5A-4	ABS403b/300A	GMC-220
	110	SV1100iP5A-4	ABS403b/400A	GMC-300
	132	SV1300iP5A-4	ABS603b/500A	GMC-300
	160	SV1600iP5A-4	ABS603b/600A	GMC-400
	220	SV2200iP5A-4	ABS803b/700A	GMC-600
	280	SV2800iP5A-4	ABS803b/800A	GMC-600
315	SV3150iP5A-4	ABS1003/1000A	GMC-800	
375	SV3750iP5A-4	ABS1203/1200A	900A	
450	SV4500iP5A-4	ABS1203/1200A	1000A	

⚡ AC Input Fuse

Voltage	Motor [kW]	Inverter Model	AC Input Fuse [A]	AC Reactor		DC Reactor	
				[mH]	[A]	[mH]	[A]
200V Class	5.5	SV055iP5A-2	40	0.39	30	1.37	29
	7.5	SV075iP5A-2	60	0.28	40	1.05	38
	11	SV110iP5A-2	80	0.20	59	0.74	56
	15	SV150iP5A-2	100	0.15	75	0.57	71
	18.5	SV185iP5A-2	125	0.12	96	0.49	91
	22	SV220iP5A-2	150	0.10	112	0.42	107
400V Class	30	SV300iP5A-2	200	0.07	160	0.34	152
	5.5	SV055iP5A-4	20	1.22	15	5.34	14
	7.5	SV075iP5A-4	30	1.14	20	4.04	19
	11	SV110iP5A-4	40	0.81	30	2.76	29
	15	SV150iP5A-4	60	0.61	38	2.18	36
	18.5	SV185iP5A-4	70	0.45	50	1.79	48
	22	SV220iP5A-4	80	0.39	58	1.54	55
	30	SV300iP5A-4	100	0.287	80	1.191	76
	37	SV370iP5A-4	125	0.232	98	0.975	93
	45	SV450iP5A-4	150	0.195	118	0.886	112
	55	SV550iP5A-4	175	0.157	142	0.753	135
	75	SV750iP5A-4	250	0.122	196	0.436	187
	90	SV900iP5A-4	300	0.096	237	0.352	225
	110	SV1100iP5A-4	350	0.081	289	Built-in	
	132	SV1300iP5A-4	400	0.069	341	Built-in	
	160	SV1600iP5A-4	450	0.057	420	Built-in	
	220	SV2200iP5A-4	700	0.042	558	Built-in	
280	SV2800iP5A-4	800	0.029	799	Built-in		
315	SV3150iP5A-4	900	0.029	799	0.090	836	
375	SV3750iP5A-4	1000	0.024	952	0.076	996	
450	SV4500iP5A-4	1200	0.024	952	0.064	1195	

Leader in Electrics & Automation



Safety Instructions

- For your safety, please read user's manual thoroughly before operating.
- Contact the nearest authorized service facility for examination, repair, or adjustment.
- Please contact qualified service technician when you need maintenance. Do not disassemble or repair by yourself!
- Any maintenance and inspection shall be performed by the personnel having expertise concerned.

LS Industrial Systems Co., Ltd.

www.lsis.biz

■ HEAD OFFICE

Yonsei Jaedan Severance Bldg., 84-11, Namdaemunno 5ga,
Jung-gu, Seoul, 100-753, Korea

Tel. (82-2)2034-4870

Fax. (82-2)2034-4713



Specifications in this catalog are subject to change without notice due to continuous product development and improvement.

■ Global Network

- **LS Industrial Systems Tokyo Office >> Tokyo, Japan**
Address: 16F, Higashi-Kan, Akasaka Twin Towers 17-22, 2-chome, Akasaka, Minato-ku Tokyo 107-8470, Japan
Tel: 81-3-3582-9128 Fax: 81-3-3582-0065 e-mail: dongjins@lsis.biz
- **LS Industrial Systems Dubai Rep. Office >> Dubai, U.A.E**
Address: P.O.Box-114216, API World Tower, 303B, Sheikh Zayed road, Dubai, UAE.
Tel: 971-4-3328289 Fax: 971-4-3329444 e-mail: hwyim@lsis.biz
- **LS-VINA Industrial Systems Co., Ltd >> Hanoi, Vietnam**
Address: LSIS VINA Congty che tao may dien Viet-Hung Dong Anh Hanoi, Vietnam
Tel: 84-4-882-0222 Fax: 84-4-882-0220 e-mail: srjo@hn.vnn.vn
- **LS Industrial Systems Hanoi Office >> Hanoi, Vietnam**
Address: Room C21, 5Th Floor, Horison Hotel, 40 Cat Linh , Hanoi, Vietnam
Tel: 84-4-736-6270/1 Fax: 84-4-736-6269
- **Dalian LS Industrial Systems Co., Ltd. >> Dalian, China**
Address: No. 15 Liaohexi 3 Road, Economic and Technical Development zone, Dalian, China
Tel: 86-411-8273-7777 Fax: 86-411-8730-7560 e-mail: lixk@lgis.com.cn
- **LS Industrial Systems (Wuxi) Co., Ltd. >> Wuxi, China**
Address: 102-A National High&New Tech Industrial Development Area, Wuxi, Jiangsu, China
Tel: 86-510-534-6666 Fax: 86-510-522-4078 e-mail: Xuhg@lgis.com.cn
- **LS Industrial Systems International Trading (Shanghai) Co., Ltd >> Shanghai, China**
Address: Room E-G, 12th Floor Huamin Empire Plaza, No.726, West Yan'an Road Shanghai 200050, P.R. China
Tel: 86-21-6278-4291 Fax: 86-21-6278-4372 e-mail: xuhg@lgis.com.cn
- **LS Industrial Systems Shanghai Office >> Shanghai, China**
Address: Room 1705-1707, 17th Floor Xinda Commercial Building, No.322, Xian Xia Road Shanghai 200336, China
Tel: 86-21-6208-7610 Fax: 86-21-6278-4292
- **LS Industrial Systems Beijing Office >> Beijing, China**
Address: B-Tower 17 Fl. Beijing Global Trade Center B/D. No. 36, BeisanhuanJong-Lu, DongCheong-District, Beijing 100013, P.R. China
Tel: 86-10-6462-3254 Fax: 86-10-6462-3236 e-mail: linsz@lgis.com.cn
- **LS Industrial Systems Guangzhou Office >> Guangzhou, China**
Address: Room 1403, 14F, New Poly Tower, 2 Zhongshan Liu Road, Guangzhou, China
Tel: 86-20-8326-6754 Fax: 86-20-8326-6287 e-mail: zhangch@lgis.com.cn
- **LS Industrial Systems Chengdu Office >> Chengdu, China**
Address: 12Floor, Guodong Building, No52 Jindun Road Chengdu, 610041, P.R. China
Tel: 86-28-8612-9151 Fax: 86-28-8612-9236 e-mail: hongkonk@vip.163.com
- **LS Industrial Systems Qingdao Office >> Qingdao, China**
Address: 7B40,Haixin Guangchang Shenye Building B, No. 9, Shangdong Road Qingdao, China
Tel: 86-532-580-2539 Fax: 86-532-583-3793 e-mail: bellkuk@hanmail.net