

R6-730 and R6-800.

Power to get your yacht up to speed.

Powered by MAN.

MAN Nutzfahrzeuge Group



Full speed ahead.

A whole fleet of MAN marine diesel engines is waiting for this command. The powerful common rail diesel engines from 730 hp to 1800 hp impress with their extraordinary dynamics, their extreme running smoothness, economy and their trend-setting environmental friendliness. The finest from modern technology.

Engine description R6-730 and R6-800.

Characteristics

Cylinders and arrangement	6 cylinders in-line
Operation mode	4-stroke diesel engine watercooled exhaust turbocharger with intercooler
Number of valves	4 valves per cylinder
Fuel system	Common Rail direct fuel injection with electronic control
Engine lubrication	Closed system with forced feeding, oil cooling and filtering
Type of cooling	Heat exchanger with engine and seawater circuit
Engine electric	Electronic injection control Electronic engine monitoring including diagnostic unit
Exhaust gas status	IMO/MARPOL 73/78, EPA Tier 2 , SAV, Recreational Craft Directive 94/25/EC
Fuel	DIN EN 590

Dimensions

A-Overall width of engine	mm	882
B-Overall length of engine	mm	1 605
C-Overall height of engine	mm	977
D-Top of engine to crankshaft centre	mm	655
E-Length of engine from front end to edge of flywheel housing	mm	1 320

For detailed examinations of installation dimensions, please order drawings from our factory.

MAN engines have outstanding qualities

- High tractive power even at low speeds
- Powerful acceleration and rapid reaction to commands
- High performance combined with low weight
- Compact, space-saving design
- Large operation range owing to low consumption
- Low running costs and long service life
- Low emission values
- World-wide service network with rapid supply of spare parts

Technical data

Type of engine		R6-730	R6-800
Displacement	l	12.82	12.82
Maximum output to DIN ISO 3046-1*	kW (hp)	537 (730)	588 (800)
Rated speed	rpm	2 300	2 300
Maximum torque	Nm	2 512	2 700
at speed	rpm	1 200 - 2 100	1 200 - 2 100
Weight (dry)	kg	1 305	1 305
Fuel consumption at rated power	l/h	145	158

* The ratings are only for operation of private yachts.

Definition of operation

The engines for light duty operation are designed for a maximum of 1 000 annual operating hours with up to 20 percent of time at full load, an average of up to 50 percent load application and no wide-open throttle below rated speed.

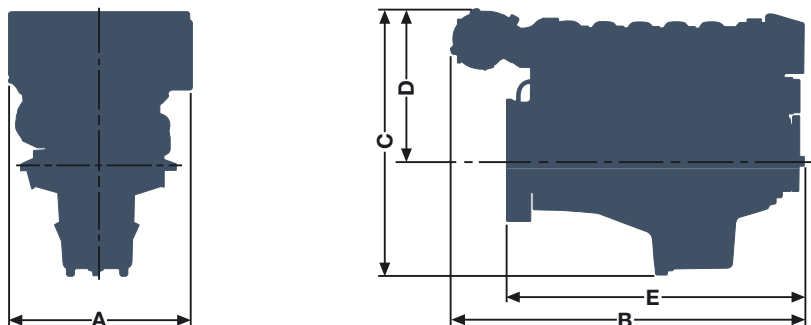

Power charts.

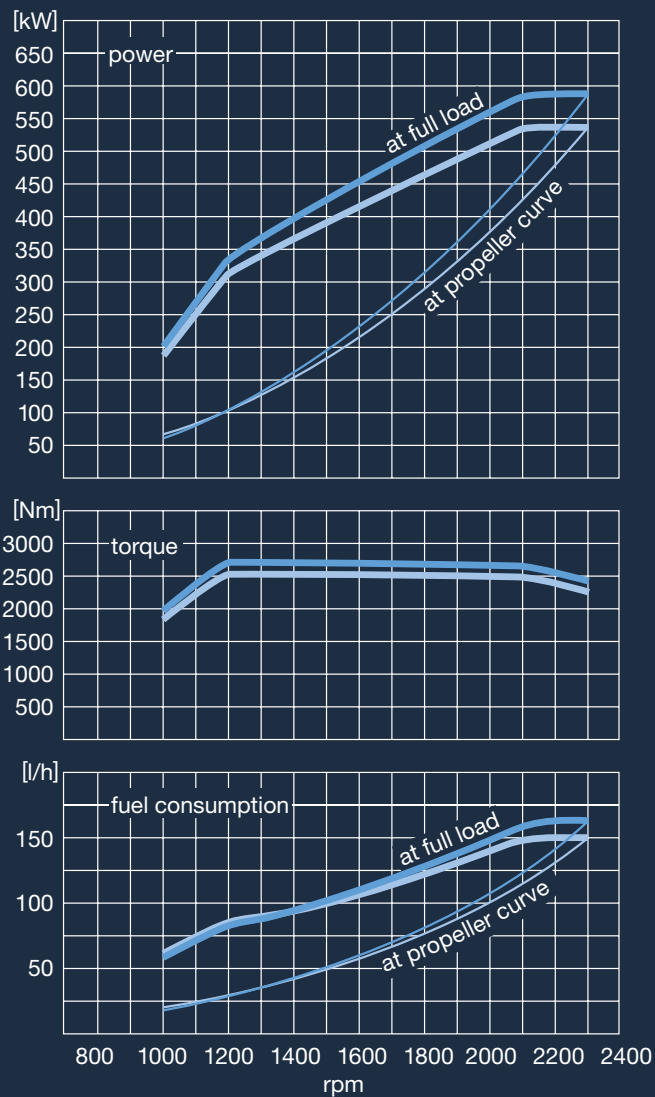

- R6 - 800 CRM, 588 kW (800 mhp)
- R6 - 730, 537 kW (730 mhp)

D 114.003/E · ms 11074 · Printed in Germany

Text and illustrations are not binding.

We reserve the right to make modifications in the course of technical progress.

MAN Nutzfahrzeuge AG
 Business Unit Engines
 Dept. MVM
 Vogelweiherstr. 33
 90441 Nuremberg, Germany

www.man-engines.com
marinemotor@de.man-mn.com

